

TRAINING CIRCULAR  
No. 90-1

HEADQUARTERS  
DEPARTMENT OF THE ARMY  
Washington, D.C., 30 September 1993  
PDF Reprint:CHQ Software

<b>TC 90-1</b>
<b>TRAINING FOR MILITARY OPERATIONS ON URBANIZED TERRAIN</b>

## CONTENTS

### PREFACE

## CHAPTER 1. INTRODUCTION

### Section I. EFFECTS OF URBAN TERRAIN

- 1-1. Limitations
- 1-2. Training Strategy
- 1-3. Definitions
- 1-4. Facilities and Programs

### Section II. DEVELOPMENT OF MISSION-ESSENTIAL TASK LIST

- 1-5. War Plans
- 1-6. External Directives

**1-7. Task List**

**1-8. Types of Evaluation**

## **Section III. BATTALION INTEGRATED TRAINING**

**1-9. Prerequisite Training**

**1-10. Individual Task Training**

**1-11. Collective Task Training**

**1-12. Risk Assessment**

## **CHAPTER 2. MOUT ASSAULT COURSE**

**2-1. Training Information**

**2-2. Typical MOUT Assault Course Station Layout**

**2-3. Station 1: Vault and Fight**

**2-4. Station 2: Clearing Techniques Building**

**2-5. Station 3: Grenadier Gunnery**

**2-6. Station 4: Destiny Doorway**

**2-7. Station 5: Dodge City**

**2-8. Station 6: Grenade House**

**2-9. Station 7: Urban Defense**

**2-10. Substation 7A: Upper-Floor Entry Techniques**

**2-11. Substation 7B: Prepared Defense**

**2-12. Substation 7C: Basement Counterattack**

**2-13. Station 8: Underground Trainer**

## **CHAPTER 3. COLLECTIVE TRAINING FACILITY**

**3-1. Description**

**3-2. Raining in the Collective Training Facility**

**3-3. Tactical Exercise Without Troops**

**3-4. MOUT Collective Training Exercises**

## **CHAPTER 4. SPECIAL MOUT CONSIDERATIONS AND LESSONS LEARNED**

## Section I. SPECIAL MOUT CONSIDERATIONS

- 4-1. The Threat
- 4-2. Precision MOUT Operations
- 4-3. Combined Arms Operations
- 4-4. Command, Control, and Communications
- 4-5. Firepower
- 4-6. Maneuver
- 4-7. Protection
- 4-8. Leadership
- 4-9. Terrain

## Section II. BATTLEFIELD OPERATING SYSTEM LESSONS LEARNED

- 4-10. Intelligence Preparation of the Battlefield
- 4-11. Maneuver-by Operation
- 4-12. Maneuver-Clearing Building
- 4-13. Maneuver-Sniper Employment
- 4-14. Fire Support
- 4-15. Mobility/Counter mobility/Survivability
- 4-16. Combat Service Support
- 4-17. Command and Control-by Operation
- 4-18. Command and Control-Liaison Officers
- 4-19. Rules of Engagement

## APPENDIX A. MOUT CLASSROOM SUBJECTS

## APPENDIX B. AUDIOVISUAL MATERIALS

## APPENDIX C. MOUT TRAINING COMPLEXES

## APPENDIX D. TRAINING TIPS

## APPENDIX E. EXAMPLE STXs AND FTXs

# APPENDIX F. EXAMPLE TRAINING PLAN

## GLOSSARY

## REFERENCES

## AUTHORIZATION

**DISTRIBUTION RESTRICTION: Approved for public release; distribution is unlimited.**

---

\*This publication supersedes TC 90-1, 9 June 1986.

---

## PREFACE

This manual provides guidance for leaders who train soldiers for military operations on urbanized terrain (MOUT). Leaders plan and conduct training so they can prepare soldiers to survive and win in urban combat. This training must follow a crawl, walk, and run sequence for individual tasks, collective tasks, and training exercises. This manual is keyed to the standard MOUT training complex, but it can also be applied to other MOUT training facilities. It is based on FM 90-10, FM 90-10-1, drill books, mission training plans (MTPs), and soldiers' manuals.

The proponent of this publication is the US Army Infantry School. Submit changes for improving this publication on DA Form 2028 directly to Commandant, US Army Infantry School, ATTN: ATSH-OTT-T, Fort Benning, Georgia 31905-5593.

Unless this publication states otherwise, masculine nouns and pronouns do not refer exclusively to men.

# CHAPTER 1

## INTRODUCTION

*This manual prepares commanders and leaders for the stress and requirements of urban combat. Chapter 1 discusses considerations for military operations on urbanized terrain (MOUT), mission-essential task list (METL), and battalion integrated training. Chapter 2 describes the MOUT assault course (MAC), which includes a new live-fire station (grenade house), and incorporates doctrine and tactics from [FM 90-10-1](#) and the ARTEP MTPs. [Chapter 3](#) describes the collective training facility (CTF) and provides layouts and training scenarios for the standard 16-building and 32-building CTFS. [Chapter 4](#) focuses on special MOUT considerations and lessons learned.*

### Section 1. EFFECTS OF URBAN TERRAIN

Friendly and enemy doctrines recommend avoiding combat in built-up areas. War in Europe, Korea, or any other heavily populated region would require MOUT. However, urban terrain, which may cover a significant geographical area, may be attacked for reasons of tactical or political necessity or because it cannot be bypassed. The increasing probability of and focus on low-intensity conflict (LIC), urban terrorism, urban insurgency, and civil disorder require that commanders and leaders increase emphasis on the tactics and techniques of urban combat.

#### 1-1. LIMITATIONS

The requirement for combat in built-up areas creates a variety of problems with troop control, maneuver, and equipment utilization. In addition, urban combat imposes demands that differ from those in conventional field conditions. These demands include requirements for a larger operational focus, a slower pace and tempo of operations, a longer duration of commitment, and continuous communications between soldiers and between units. Urban combat could also require either longer or no preparatory and counterpreparatory fires. The ROE may prohibit such fires, or the commander may do so to limit rubble.

- a. The success of urban defensive operations and insurgent or terrorist actions depends on holding or attacking critical areas that provide psychological advantages, stability, and freedom of maneuver to whoever possesses them. Either way, combat in urban areas breaks down into many small-unit battles. These battles are fought by battalions, companies, platoons, and squads; or, in confined areas, they are fought by small assault groups. These small-scale battles make centralized control difficult, requiring small-unit leaders to independently employ mission tactics.
- b. Confined spaces limit observation, fields of fire, and maneuver. Restrictive maneuver requires detailed planning to synchronize combat power at decisive points. The confined spaces of an urban environment also limit the employment of firepower. Combat power may be further reduced by the requirement (in the rules of engagement) to minimize collateral damage. Small-unit leaders must

be resourceful and innovative, and must fully employ the other elements of combat power—maneuver, protection, and leadership—to compensate for the constant use of firepower. Leaders must also train soldiers to use precision weapons confidently.

c. Logistical elements are strained by the increased demand for ammunition, high casualty rates, and transportation difficulties in MOUT.

d. Reconnaissance during MOUT is difficult and time-consuming, but is the best source of intelligence for the commander.

## **1-2. TRAINING STRATEGY**

Urban terrain conditions challenge the trainer. The MOUT training program must focus on developing tough, realistic training to ensure combat readiness. FMs [25-100](#) and [25-101](#) explain how to determine a unit's METL and battle tasks, and how to plan, provide resources for, and execute training events. Specific FMs, TCs, and ARTEP MTPs provide the tactics, techniques, and procedures (TTPs) and standards to conduct and evaluate training. A complete training program emphasizes physical fitness, weapons marksmanship, and individual skills through collective task proficiency.

a. Limited visibility training and live-fire training should be conducted routinely to prepare soldiers and leaders for combat conditions.

b. During live-fire exercises, soldiers should train in the use of demolitions and should understand the terminal effects of munitions on urban terrain. Training events should encourage subordinate leaders to use their initiative and take independent action to prepare for the decentralized operations that characterize MOUT. Squad leaders, platoon sergeants, platoon leaders, commanders, and staffs are the primary training managers and trainers (Figure 1-1).

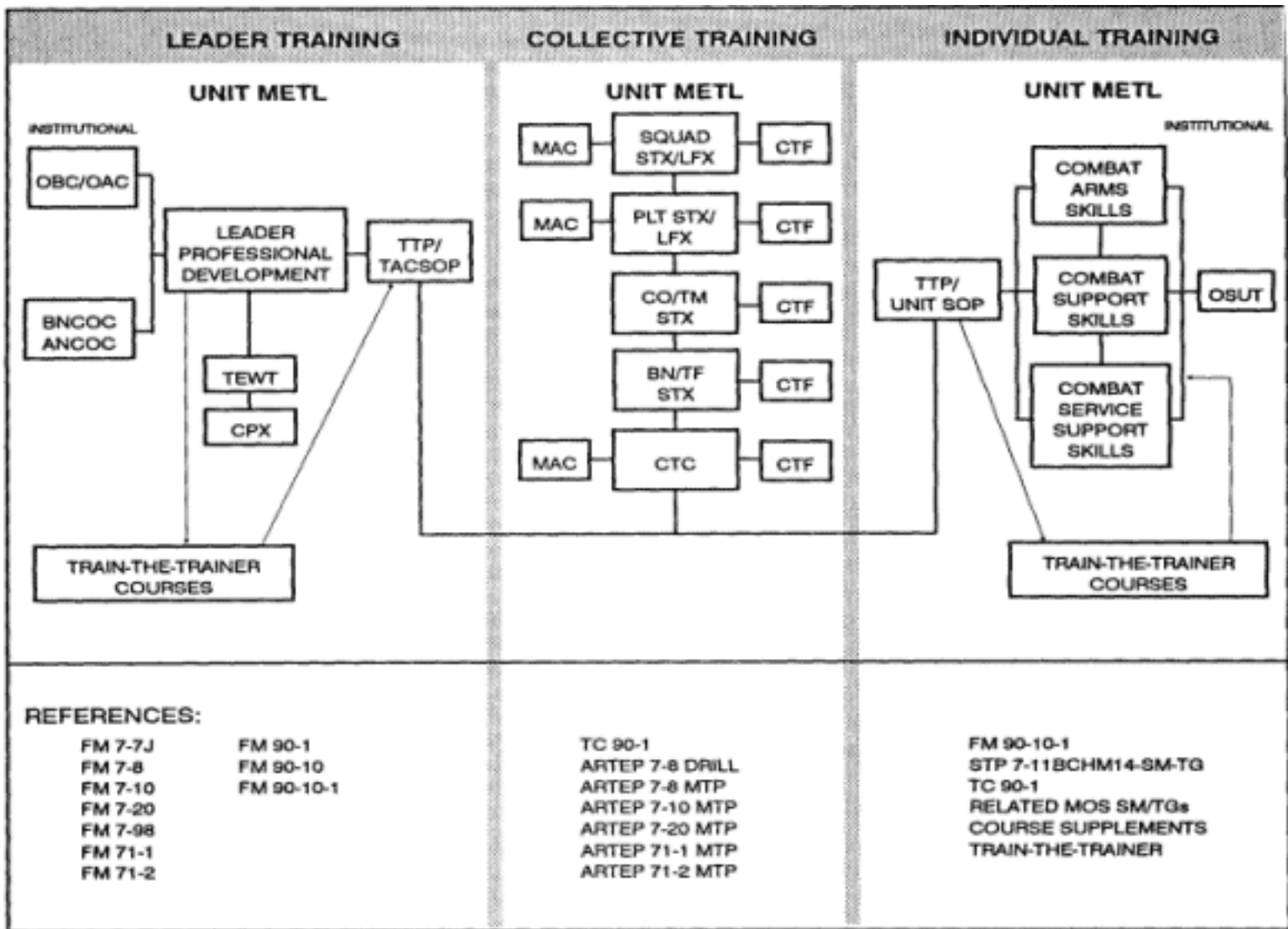

Figure 1-1. MOUT training program.

### 1-3. DEFINITIONS

FMs [90-10](#) and [90-10-1](#) define MOUT and MOUT-related terms as follows:

- a. **Military Operations on Urbanized Terrain.** These include all military actions that are planned and conducted on terrain where man-made construction affects the tactical options available to the commander. These operations are conducted to defeat an enemy who may or may not be separated from civilians. Consequently, the ROE and use of combat power are more restrictive than in other combat conditions.
- b. **Built-Up Areas.** These are concentrations of structures, facilities, and people. They form the economic and cultural focus for the surrounding area. The four categories of built-up areas include large cities, towns and small cities, villages, and strip areas.
- c. **Surgical Military Operations on Urbanized Terrain.** These operations are normally conducted by SOF. They include raids, recovery operations, rescues, and other special operations.
- d. **Precision Military Operations on Urbanized Terrain.** These operations are conducted by conventional forces to defeat the enemy when he is mixed with noncombatants. Therefore, they are conducted carefully to limit noncombatant casualties and collateral damage and prevent friendly

fire casualties. This type of operation requires strict accountability of individual and unit actions through strict ROE; it also requires specific TTP for precise use of combat power.

## 1-4. FACILITIES AND PROGRAMS

Training managers must select their training objectives and train them realistically, efficiently, and effectively to high standards.

a. **Garrison.** Many urban combat skills and tasks can be taught in garrison. These include classroom subjects such as classification of buildings, legal aspects of MOUT, and effects of weapons on urban structures ([Appendix A](#)). Useful audiovisual training aids may be obtained from local TSCs ([Appendix B](#)).

b. **MOUT Training Complex.** The MTC is a mock urban area. Since the high demand for this resource limits its availability, the MTC is used to train only the skills and tasks that cannot be trained in other areas. Though individual skills and collective tasks unique to built-up areas are emphasized, training in the MTC also reinforces skills relevant to any combat environment. Leaders and soldiers find many of the same challenges they would face in real urban combat. ([Appendix C](#) provides a list of locations of MOUT training facilities.) The complex has the following parts:

(1) **MOUT assault course.** Soldiers can practice individual urban combat skills in the MAC, such as building an individual TOW position or clearing a room. ([ARTEP 7-8-MTP](#), Chapter 2, provides leaders with a collective task-to-individual task matrix.) Leaders must require that soldiers practice until they meet training standards. This ensures they are prepared for combat in built-up areas. Individual skills form the basis for training units in the collective tasks essential to this type of combat. ([Chapter 2](#) discusses the eight MAC training stations.)

(2) **Collective training facility.** Units from battalion level down can practice collective tasks in the CTF that are unique to combat in built-up areas. ([Chapter 3](#) provides more detailed information about CTFs.) The units learn to perform a variety of missions to include raids, ambushes, underground reconnaissance, and control of civil disturbances in a built-up area.

c. **Program of Instruction.** Every POI should follow a *crawl, walk, run* sequence, based on clearly defined standards.

(1) **Crawl.** The trainer explains each task's training objective and performance standards. He talks the soldiers through the exercise, step by step, describing what each individual or unit must do. This often includes a demonstration.

(2) **Walk.** The soldiers slowly practice each task to standard. Trainers coach soldiers at this stage, stopping as often as needed to correct mistakes and provide feedback. Soldiers practice each task repeatedly until they can perform it without error.

(3) **Run.** Soldiers perform each task at full speed as if they are in combat. They need feedback during this stage as well. The following can be used to enhance realism:

- Blank ammunition.

- Plastic ammunition.
- Pyrotechnics.
- Multiple Integrated Laser Engagement System (MILES).
- Opposing forces.
- Nuclear, biological, and chemical simulation.
- Training in limited visibility conditions.

d. **After-Action Review.** Leaders conduct an AAR after each training event to help soldiers and units improve their skills by providing immediate feedback. An AAR is a useful tool: it increases the benefits gained from each training exercise by allowing the leader and soldiers to work together to analyze the performance of each task. Being involved in this analysis enables the soldiers to learn and retain more than they would if they were simply critiqued. An AAR improves the performance of soldier, leader, and unit tasks and provides the commander with some of the information and insight he needs to assess the training (Appendix D).

e. **Scenarios.** Leaders should think "combined arms" when preparing their training. Scenarios should combine combat, CS, and CSS elements as they apply ([Appendix E](#)). Trainers must then use their initiative and imagination. The result is productive training and a unit ready for battle in built-up areas. Support units can practice their wartime missions in the CTF—for example:

- (1) Aviation units can perform air assault and MEDEVAC missions.
- (2) Military police can practice traffic and refugee control.
- (3) Engineers can prepare or breach obstacles.
- (4) Logistical units can conduct sustainment operations.
- (5) Medical units can hold mass casualty exercises.
- (6) Personnel units can process replacements in an urban setting.
- (7) Signal units can establish, maintain, or modify communications systems to support the operation.

## **Section II. DEVELOPMENT OF MISSION-ESSENTIAL TASK LIST**

The unit's wartime mission—its battle focus—drives the METL-development process. The METL then drives the development of the unit's training program and direction, because the unit must train as it plans to fight. A METL is needed because units cannot obtain proficiency on every possible task. The tasks chosen for inclusion in the METL are those that are key to the unit's success on the battlefield. The commander develops his METL from the unit's wartime mission and external directives, then he allocates time and resources to train these tasks.

### **1-5. WAR PLANS**

War plans identify the unit's MOUT tasks and battle tasks. The rules of engagement define the unit's MOUT perspective: whether conventional, surgical, or precision MOUT operations. Senior commanders must set specific MOUT "condition" guidance and directives for unit MOUT TTPs and must develop unit SOPs. The SOPs ensure that MOUT tasks and missions are performed efficiently and to standard. The SOPs also enhance unit interoperability up to the division level and enhance the fighting capability of heavy/light integrated forces. The establishment of these command directives and SOPs helps the unit avoid fratricide during combat operations.

## **1-6. EXTERNAL DIRECTIVES**

External directives are additional sources of wartime tasks that relate to the unit's wartime mission. These include mobilization plans, installation wartime transition and development plans, force integration plans, ROE plans, and specific MOUT application plans (surgical and precision). The commander and operations staff use [FM 90-10](#), [FM 90-10-1](#), appropriate common task and skill level manuals, and institutional MOUT knowledge to develop TTPs and SOPs. The commander uses the specific conditions prevailing in surgical and precision MOUT to further refine his guidance and directives. The highest appropriate level in the chain of command must address these conditions.

## **1-7. TASK LIST**

The commander, with assistance from staff, NCOs, and other leaders in his unit, identifies and develops all the tasks, TTPs, and SOPs. MTPs, soldier's manuals, and drill books serve as references for this effort. The commander then identifies the tasks most critical to success. These tasks compose the unit's METL. Tough, realistic training confirms, modifies, or denies the MOUT-specific TTPs and SOPs for the unit's MOUT METL. (Figure 1-2 shows the MOUT evaluation echelon relationship.)

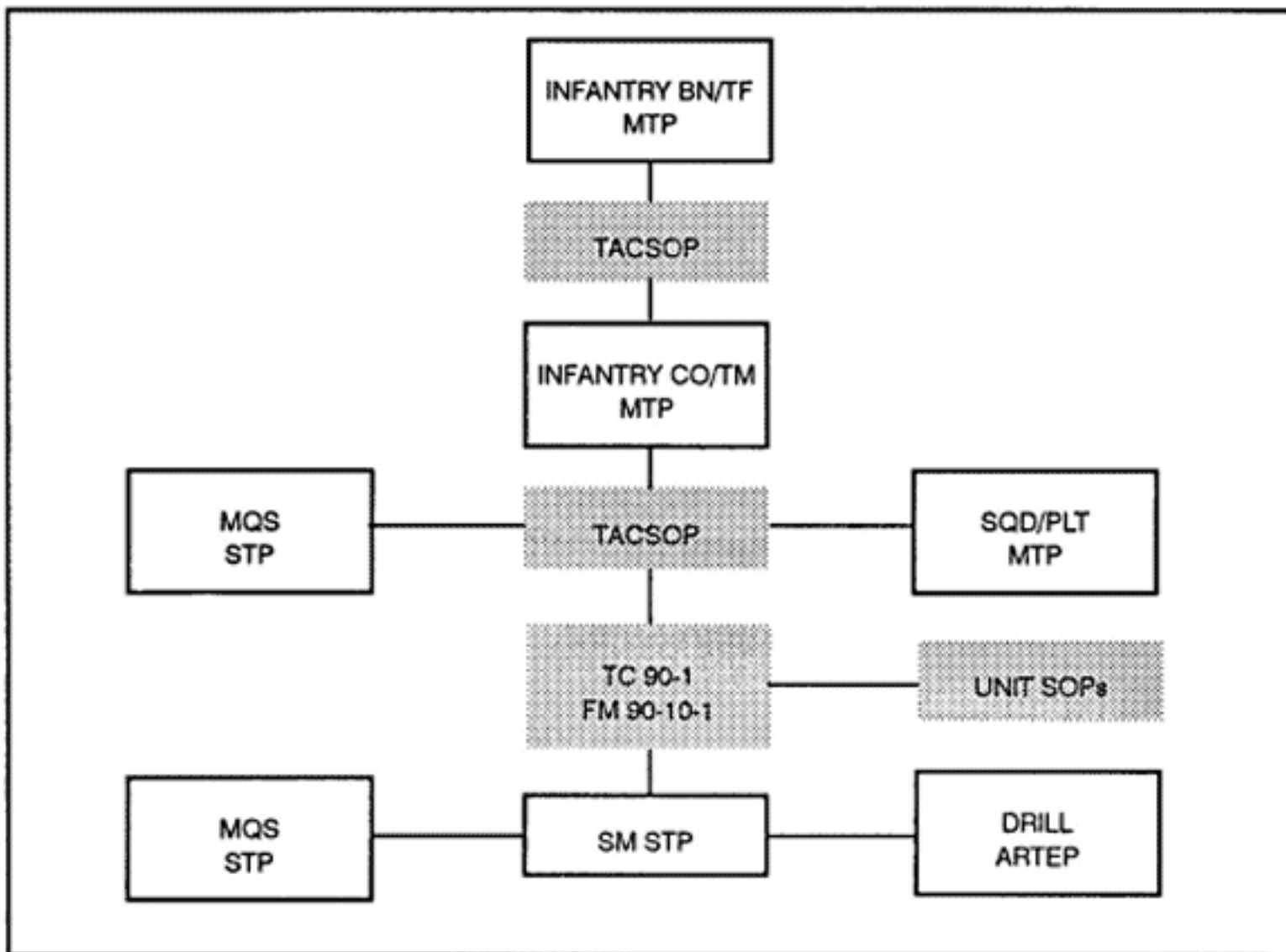

**Figure 1-2. MOUT echelon relationship.**

## 1-8. TYPES OF EVALUATION

Leaders use training and evaluation outlines along with training objectives to determine if the unit's task proficiency meets Army standards found in ARTEPs (drills and MTPs). The evaluation process is continuous. Evaluators use T&EOs and the unit's training objectives to determine if the standards established by the MTPs are met. Therefore, leaders should plan evaluations for all training. These evaluations can be informal or formal, internal or external.

- a. **Informal Evaluation.** Leaders conduct informal evaluations during ongoing training. The development and refinement of MOUT-specific crew, team, and squad TTPs and SOPs that support the MOUT-related collective task are based on the AARs from these evaluations.
- b. **Formal Evaluation.** Dedicated evaluators conduct formal evaluations, which are scheduled on the long-range or short-range training plan. The unit's MOUT tactical techniques and SOPs should be validated during this type of evaluation.
- c. **Internal Evaluation.** The unit plans, resources, and conducts internal evaluations. By conducting this type of evaluation, the unit can refine its MOUT tactical techniques and SOPs and also resolve the adjacent and higher unit interoperability issues specific to MOUT.

d. **External Evaluation.** Higher headquarters or another unit plans, resources, and conducts external evaluations. Units must submit their MOUT-specific tactics, techniques, and SOPs to the evaluating unit to fill the assessment gap for the corresponding MOUT collective tasks.

### Section III. BATTALION INTEGRATED TRAINING

The battalion commander and his staff establish the battle focus of the battalion's MOUT training plan before the training plan is executed. Units conduct prerequisite training before deploying to the MOUT training facility. Once deployed, the units train individual tasks at the MAC. Units conduct leader and collective training at the collective training facility.

#### 1-9. PREREQUISITE TRAINING

Prerequisite training teaches individuals what they need to know before they can perform a task. To build teamwork, crews, teams, and squads should conduct prerequisite training at command and staff, leader, and individual soldier levels. A tough, MOUT-focused PT program prepares soldiers for the physical stress of urban training and combat.

a. **Command and Staff Training.** The battalion battle staff and leadership must train themselves before the battalion's collective training, honing their skills and preparing to train subordinates. Primary staff, special staff, and leaders of supporting elements should prepare to conduct battle staff operations in MOUT. The staffs also direct the MOUT training plans for their staff sections. During prerequisite training, the staffs are the main trainers for battalion leadership development courses. The battalion command and staff should culminate their prerequisite training with a MOUT TEWT and a MOUT CPX. This helps define and refine the battalion's tactical standing operating procedure (TACSOP). This MOUT "scrubbing" of the battalion's TACSOP establishes the initial "top-down" TTP and SOP development guidance to the subordinate units.

b. **Leader Training.** A comprehensive leader training program is the key to successful MOUT training. Time spent teaching battalion leaders (trainers) during the planning and preparation phase ensures MOUT training to standard. Leader training refreshes institutional knowledge (OBC, OAC, BNCOC, or ANCOC), current MOUT doctrine ([FM 90-10](#), [FM 90-10-1](#), TC 90-1), and unit knowledge (based on experience and prior training events). These refresher courses take the form of supplemental leadership development courses and training meeting agendas. Recommended subject areas include threat analysis, urban area and building analysis, weapons effects on urban structures, MOUT attack and defense, MOUT TTP, and SOP development.

c. **Individual Training.** Many MOUT-specific tasks and skills can be trained, sustained, and maintained in a barracks environment. Other tasks can be trained at local obstacle courses, leadership reaction courses, and weapons ranges. The *crawl* phase of task training can be accomplished before the collective MOUT training density. The unit should focus on three general areas for preliminary training: urban combat skills, urban marksmanship skills, and urban physical fitness skills.

(1) The following are examples of preliminary training tasks:

(a) Urban combat skills, as explained in [FM 90-10-1](#), are trainable in a barracks area,

and include—

- Individual movement techniques.
- Battle drills.
- Weapon positioning in an urban area.
- Roadblock and vehicle search procedures.
- Dismounted and mounted urban navigation.

(b) Urban marksmanship skills include—

- Urban scanning techniques.
- Quick fire techniques.
- Assault fire techniques.
- Hasty urban firing positions.
- Prepared urban firing positions.

(2) During marksmanship densities before MOUT collective training cycles, trainers can develop MOUT-specific firing conditions in conjunction with weapons firing ranges. All weapons should be fired in urban conditions during training. Facades can be built on existing ranges, or the unit can use their local MAC (if available).

(a) Urban combat skills include—

- Firing positions behind rubble, around corners, from windows or roofs.
- Urban targets behind rubble, in windows and doorways.
- Fire commands.
- Lifting and shifting fires from lower to upper story windows.
- Fire control and fire discipline.
- Rapid firing engagements.
- Rules of engagement firing scenarios.

(b) Urban physical fitness skills include—

- Endurance runs and upper body conditioning.
- Rope climbing and vaulting exercises.
- MOUT-specific obstacle course negotiation.
- Leadership reaction course (LRC) negotiation.

## 1-10. INDIVIDUAL TASK TRAINING

MOUT requires the soldier to be proficient in several individual tasks unique to urban fighting. Additional urban fighting techniques have been developed based on combat lessons learned and on evolving technology.

a. Army doctrine includes three individual MOUT-specific tasks:

[STP 7-11BCHM14-SM-TG](#):

<071-326-0541—Perform Movement Techniques During MOUT.

071-326-0550—Prepare Positions for Individual and Crew-Served Weapons During MOUT.

071-326-0557—Select Hasty Firing Positions During MOUT.

b. Soldiers must construct and employ roadblocks and barriers. Though units can also train to specific military police task standards, the following tasks correspond to employment of obstacle tasks:

STP 19-95B1-SM:

091-376-4106—Establish and Operate a Roadblock and Checkpoint.

STP 19-95B24-SM-TG:

191-377-4203—Establish/Supervise a Roadblock/Checkpoint.

191-379-4402—Plan Roadblocks and Checkpoints.

c. [FM 90-10-1](#), Chapter 5 discusses the following combat skills:

(1) ***Movement techniques.***

- Crossing a wall.
- Moving around corners.
- Moving past windows.
- Using doorways.
- Moving parallel to buildings.
- Crossing open areas.
- Employing fire teams.
- Moving between positions.
- Moving inside a building.

(2) ***Entry techniques.***

- Entering at upper levels.
- Using a ladder.
- Using a grappling hook.
- Scaling walls.
- Rappelling.
- Entering at lower levels.
- Using hand grenades.

(3) ***Firing positions.***

- Hasty firing position.
- Prepared firing position.

- Target acquisition.
- Flame operations.
- Employment of snipers.

(4) *Navigation in built-up areas.*

- Applying camouflage.
- Using shadows.
- Using color and texture.

d. The following entry techniques are covered in resources other than [FM 90-10-1](#). Soldiers may seek this information based on the availability of the references and on the ROE:

- Entry by fast rope from helicopter.
- Use of civilian resources such as fire engine ladder trucks, utility trucks with lifts, bulldozers, and jackhammers.
- Entry below the surface.

e. Having accomplished the *crawl* phase during preliminary training, the battalion can spend the first part of the training density *walking* and *running* those tasks. Task stations and STX lanes are effective for conducting MOUT individual through squad supporting task training. Figure 1-3 shows an example of task stations and STX lanes in a 32-building collective training facility (CTF) (Chapter 3). The task stations chosen are adapted for MOUT from operations, tasks, techniques, and skills described in [FM 7-8](#), [FM 90-10-1](#), and [FM 90-13-1](#). Training strategy for choosing the training technique to be used is based on the following:

- The availability of the MOUT CTF.
- The duration of the training density at the MOUT CTF.
- The desired degree of technique standardization within the battalion, company, platoon, or squad.
- The level and number of qualified trainers.

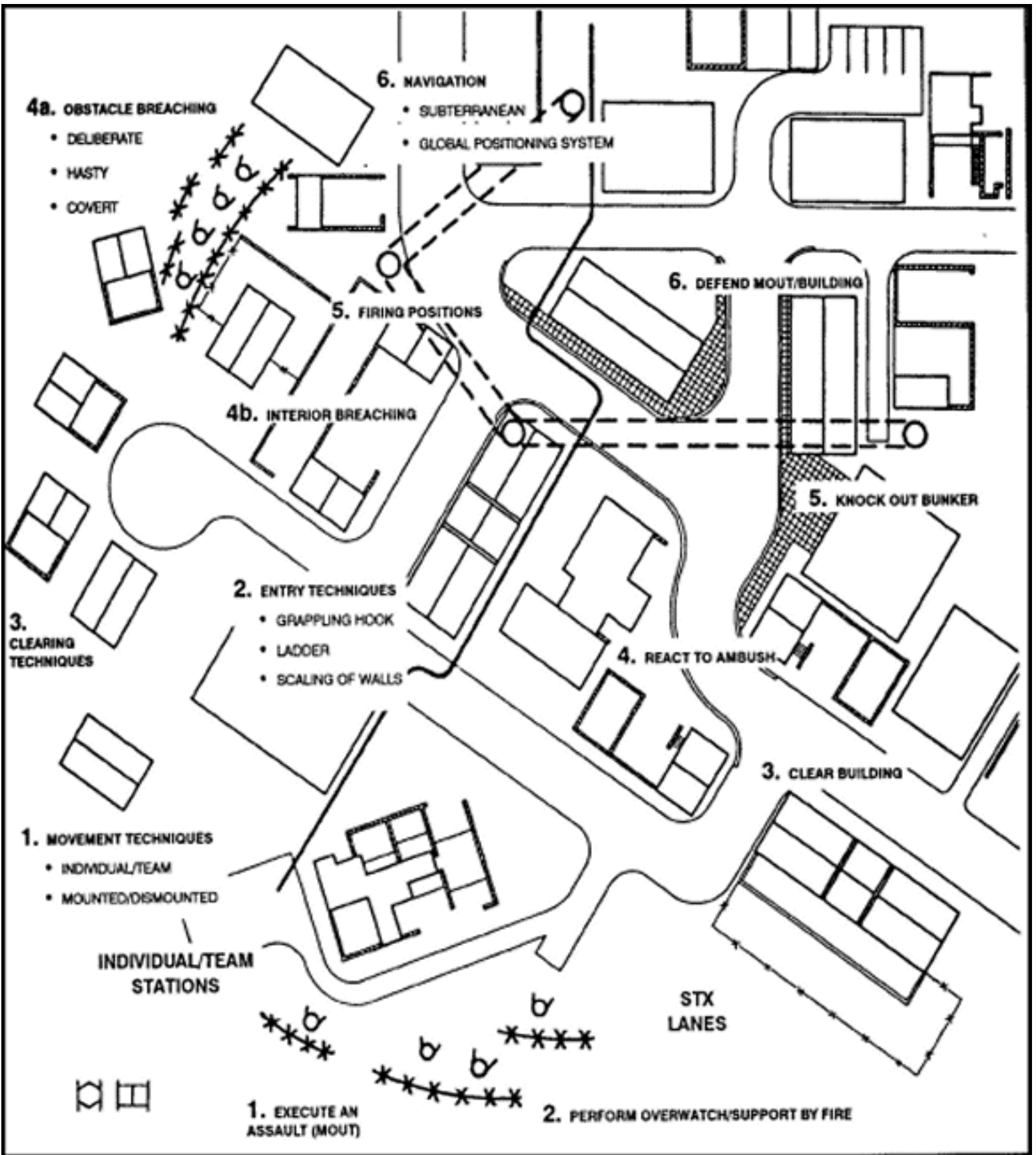

Figure 1-3. Individual-squad supporting task training scheme.

### 1-11. COLLECTIVE TASK TRAINING

Squads, platoons, and companies train on collective tasks IAW ARTEP MTPs. However, only a few of

these tasks specifically address MOUT; the others must be adapted for the MOUT environment.

a. MOUT-specific tasks at squad and platoon level include the following:

[ARTEP 7-8-MTP:](#)

7-3/4-1134—Move Tactically.

7-3/4-1110—Clear a Building.

7-3/4-1118—Defend MOUT/Building.

b. MOUT-specific tasks for the infantry company, combat team, and infantry battalion are as follows:

[ARTEP 7-10-MTP:](#)

7-2-1134—Move Tactically.

7-2-1109—Execute an Assault (MOUT).

7-2-1118—Defend MOUT/Building.

[ARTEP 71-1-MTP:](#)

17-2-0301—Perform Tactical Movement.

[ARTEP 7-20-MTP:](#)

7-1-1115—Execute Defense.

7-1-1100—Execute Attack.

c. The commander must use the battalion integrated training plan to establish the goals of the training density. He focuses on combined arms operations, emphasizing dismounted infantry maneuver. Tanks and BFVs mainly provide supporting fires for the dismounted elements. The CS elements must be integrated at every level to ensure the battalion is prepared to fight as a task force. The battalion CSS system is stressed during MOUT operations. The commander must deploy his CSS elements to the field to support training just as he would for sustainment operations in war. The conditions of the urban environment—resupply, casualty evacuation, maintenance, and sustainment—should be trained concurrently at every level within the battalion.

(1) Training goals should include the following:

- (a) Finalize individual and crew, team, or squad combat skills and TTPs in a tough, realistic training environment.
- (b) Conduct squad live fire at the MAC.
- (c) Conduct squad through company force-on-force exercises with MILES.
- (d) Integrate CS and CSS assets into the training plan.

(e) Conduct corresponding AARs (TSC video support).

(f) Retrain or reinforce appropriate tasks.

(2) The battalion commander and the S3 can use a variety of methods to organize the MOUT training density. Which method they choose depends on how long the battalion has access to the MOUT CTF or the MAC, and on whether the MOUT facility has 32 or 16 buildings. The commander can plan company rotation through the CTF and MAC, or through shared facility training of the CTF and MAC. Regardless of which method the commander chooses, the individual training should support the collective training plan and accomplish the battalion training goals ([Appendix F](#)).

## 1-12. RISK ASSESSMENT

Risk assessment means making operations safer without compromising the mission ([FM 25-101](#)). Commanders must continuously assess the risk of training conditions to prevent unnecessary loss of soldiers and equipment. Degree of risk depends on conditions. Just as this principle applies to other training and warfighting, it applies to MOUT. In a training situation, for example, commanders must determine whether soldiers and leaders have conducted this type of training before, whether initial training will be conducted at night, and whether soldiers are tired. Risk assessment ensures MOUT training is not only tough and realistic but also safe. Training enhancers, such as live fire, blank ammunition, simulators, fires, smoke, and other pyrotechnics, must be employed fully to achieve training objectives. Soldiers must wear earplugs, protective vests, and protective eye wear to protect themselves from the noise and the debris of MOUT operations. ([Chapters 2](#) and [3](#) discuss other specific safety considerations.)

a. Commanders integrating risk assessment and safety considerations into their training plans must—

(1) Accept no unnecessary risks.

(2) Ensure risk decisions are made at the appropriate level. In MOUT, these decisions may be made by the team leader.

(3) Accept risks if mission benefits outweigh costs.

b. The commander considers risk and safety in special MOUT training situations such as—

(1) Soldiers engaging in close quarters combat in an urban environment, for example, may need to fire blanks while they enter a building or room. They are unaware of the exact location of the OPFOR and of their proximity to OPFOR flash suppressors, booby traps, and practice hand grenades.

(2) Soldiers use ladders, ropes, and grappling hooks to enter buildings at upper stories, which creates the potential for dangerous falls.

(3) Soldiers may inhale the screening smoke that builds up inside rooms, unless they are wearing protective masks.

c. The commander is the safety officer, but all soldiers and leaders are responsible for safe

training. All leaders must—

- (1) Use METT-T factors to identify risks.
- (2) Assess possible losses and their costs.
- (3) Select and develop risk-reduction measures.
- (4) Implement controls by integrating them into plans and orders, SOPs, training performance standards, and rehearsals.
- (5) Supervise and enforce risk-reduction measures and safety standards at all times.

## CHAPTER 2

# MOUT ASSAULT COURSE

*The MAC contains eight stations: urban defense, underground trainer, vault and fight, clearing techniques building, grenadier gunnery, destiny doorway, Dodge City, and grenade house. These stations are designed for individual tasks and for small-unit collective tasks.*

### 2-1. TRAINING INFORMATION

Many types of organizations with a variety of missions can train at the MAC. Tactical operations in a MOUT environment may range from normal tactical missions to peacekeeping, riot control, or police actions. The structures at the stations might need adjusting to accommodate different types of units and missions. Commanders should note that MACs are unsuited to cannon fire; their layout does not allow for movement or for acquisition of vehicular targets within the built-up area. Vehicle employment for suppressive fire depends on individual range fans and limitations.

a. The following information is provided for each MAC station, if applicable. Units should add or delete data to meet their training requirements:

(1) **Description.** This describes the station and its layout, including wall construction, number of rooms, and locations of rubble and cover. The urban terrain of the unit's METL may require that trainers modify the buildings.

(2) **Targetry.** Targets may be moved, modified, or added as required by the training requirements of the unit's METL. For example, some personnel targets maybe dressed in civilian clothing to help soldiers identify friends and foes during precision MOUT training.

(3) **Purpose.** This indicates the original purpose of each station. Units may use the station in the manner originally planned, or they may modify it to meet their own training requirements.

(4) **Controller requirements.** This lists minimum requirements. The unit may actually require more personnel than listed.

(5) **Safety requirements.** This information is given for each station, whether or not it accommodates live fire. The unit or range control at the MAC site may mandate additional safety requirements.

(6) **Individual MOUT tasks or skills trained.** These are listed for each station. However, [ARTEP 7-8-MTP](#), Chapter 2, contains a complete list of related common, individual, and MOUT-specific training and evaluation outlines (T&EOs).

(7) **Applicable leader tasks.** This is a list of leader tasks and MOUT-specific skills from [ARTEP 7-8-MTP](#) that applies to each station.

(8) **Support requirements.** This lists minimum material requirements to support training at each station. The unit must specify other materials needed for training.

b. Soldiers can train in the MAC using blanks, plastic ammunition, practice grenades, MILES, or live fire. Guidelines that apply to specific stations follow:

(1) Blanks, MILES, or practice grenades are the only ammunition suitable for training at the urban defense and underground trainer stations. Live fire *may not be used* at these stations.

## **DANGER**

**Using live grenades at any station except the grenade house could injure or kill you.**

(2) Live fire and plastic ammunition may be used at the following six MAC stations, along with blanks, MILES, and practice grenades ([TC 7-9](#)):

- Vault and fight.
- Clearing techniques.
- Grenadier gunnery.
- Destiny doorway.
- Dodge City.
- Grenade house.

(3) Live fragmentation and concussion grenades are authorized *only at the grenade house*.

## **DANGER**

**Never cook off live grenades in training. Doing so could injure or kill you. You may cook off practice grenades, but only with adequate training and supervision.**

## **2-2. TYPICAL MOUT ASSAULT COURSE STATION LAYOUT**

The details of a typical MAC layout (Figure 2-1) might differ from those of a local MAC layout. The training potential of a local MAC can be increased by adapting the training sequence to suit it. Each station is designed to support individual and collective tasks. The leader must stress safety and must develop and implement safety measures to guard against injuries. [Appendix C](#) provides the locations of existing MAC facilities. A useful manual, [HNDM 1110-1-7](#), may be obtained by writing to the following address:

Commander  
U.S. Army Engineer Division, Huntsville (USAEDH)  
ATTN: CEHND-ED-PM  
P.O. Box 1600  
Huntsville, AL 35807-4301

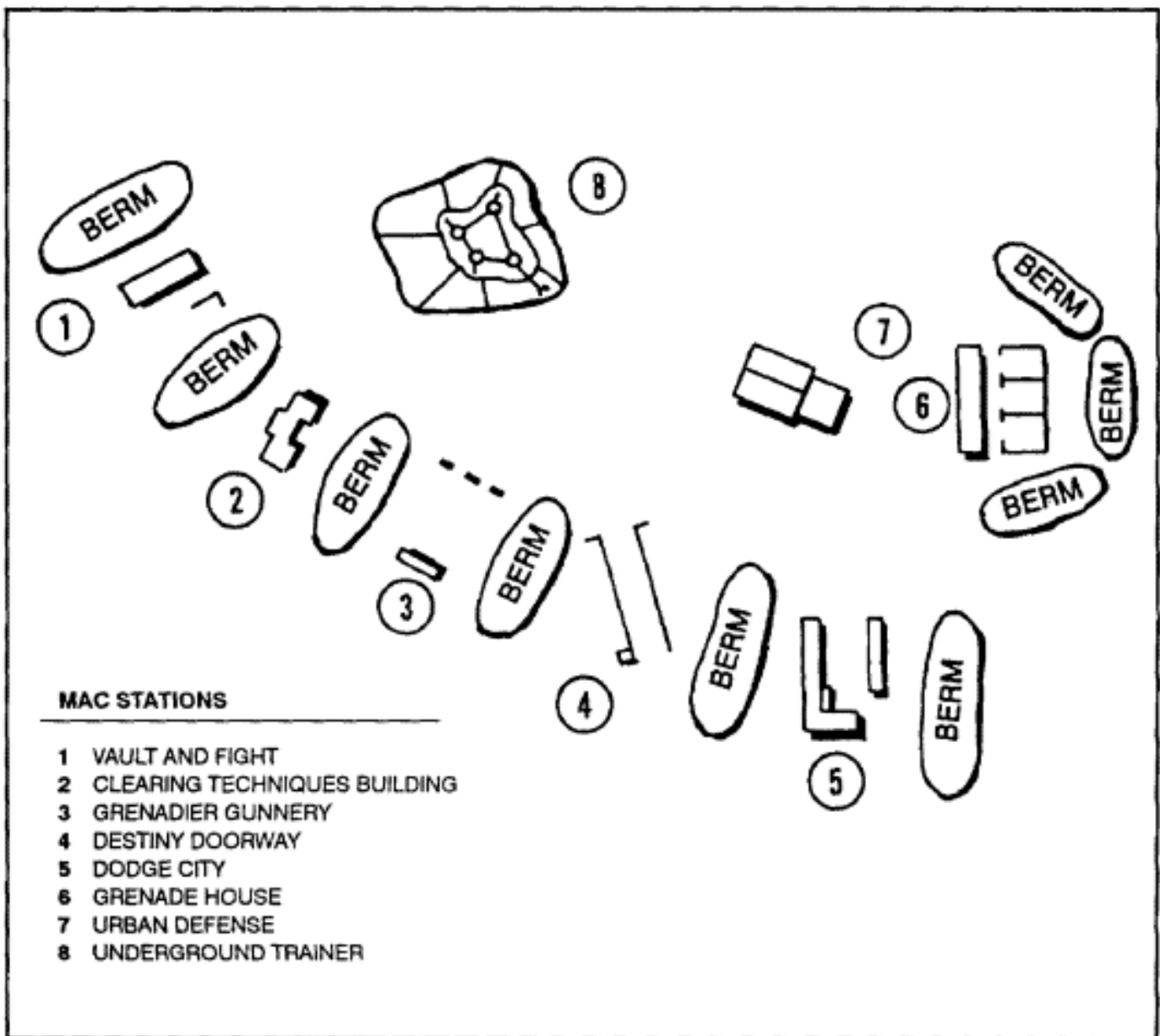
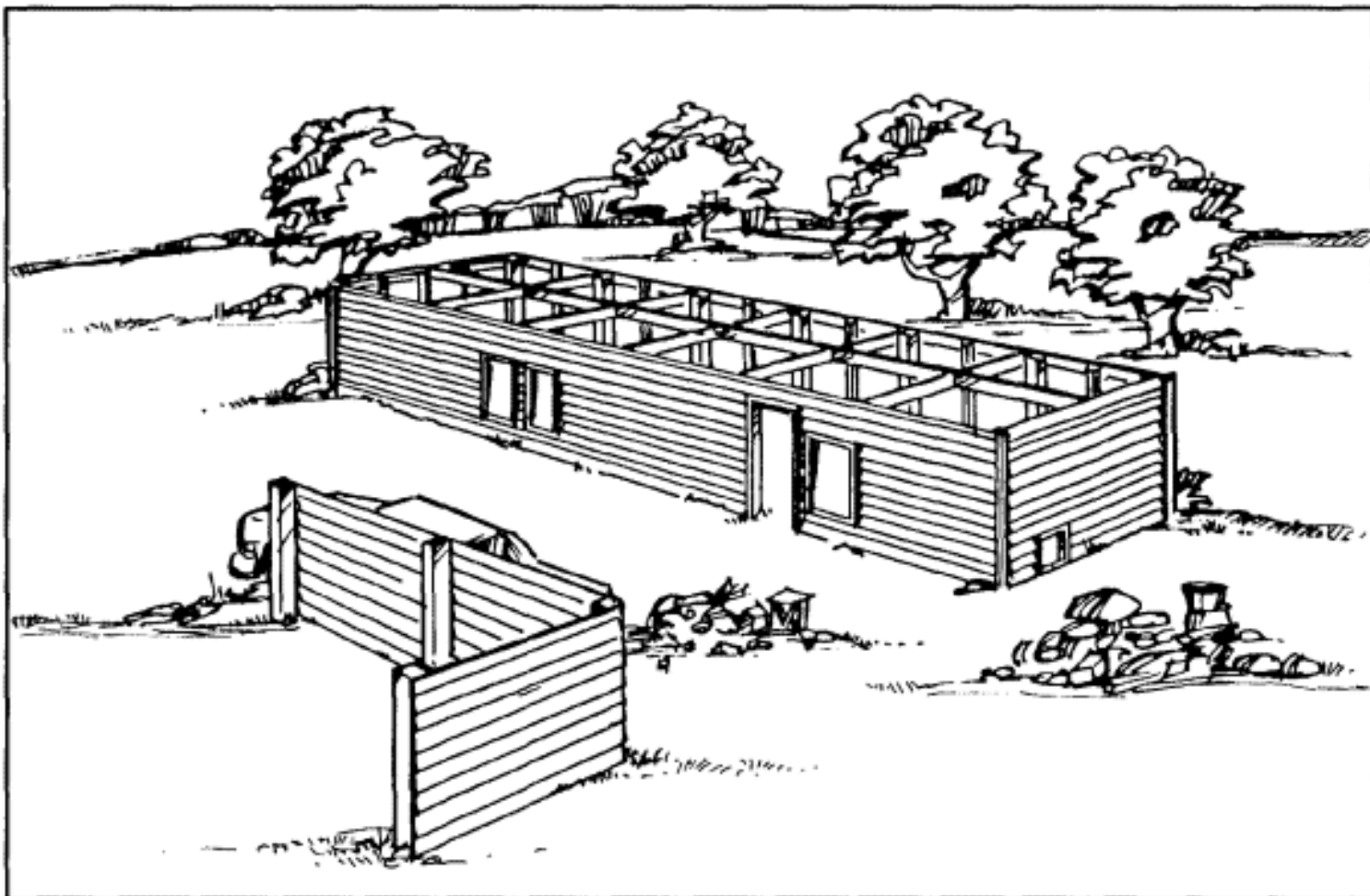

Figure 2-1. Typical MAC layout.

### 2-3. STATION 1: VAULT AND FIGHT

The stations in the MAC are used to train a dismounted infantry squad. However, the unit's training requirements determine the size of the unit and the tasks to be trained at each station. The unit develops its organization and steps for conducting the exercise based on its METL tasks and on its training needs. Live fire *may be used* at this station (Figure 2-2).



**Figure 2-2. Vault-and-fight station.**

a. **Description.** This station has two parts:

(1) The first is an L-shaped wooden wall about 8 feet high by 20 feet long.

(2) The second is a wooden facade that looks like a one-story building. The short side of the facade has a preconstructed mousehole (small opening or passageway) at ground level. The long side has three windows and a doorway. The roof and the other two outside walls are made of target cloth. A wood interior wall has a door that divides the building into two rooms. Cover, such as rubble or wrecked vehicles, is located opposite the wooden sides of the facade.

b. **Targetry.** This station has four automated targets. Two appear in the windows of the facade. One appears in the far corner inside each of the two rooms (Figure 2-3).

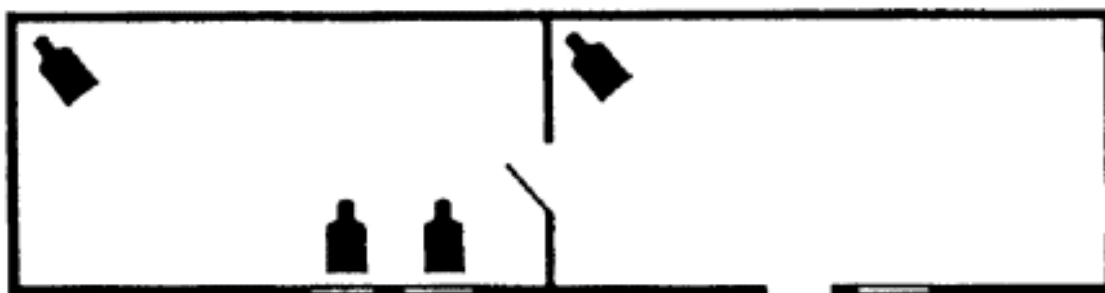

**Figure 2-3. Targetry, vault-and-fight station.**

c. **Purpose.** This station may be used to train soldiers to do the following:

- Cross obstacles.
- Check and mark booby traps.
- Provide fire support.
- Use smoke grenades.
- Use demolitions.
- Enter a building.
- Clear a room.

d. **Controller Requirements.** The chief controller (usually the squad or platoon leader) has one assistant to operate targetry,

e. **Safety Requirements.** Leaders must train their units to safely execute MOUT missions.

(1) Only *practice* grenades or *grenade simulators* may be used on this range.

(2) The detonation of the practice hand grenade may produce too little noise to signal the support force to cease or shift fires. The leader must observe the soldier designated to throw the grenade. When the grenade is thrown, the leader orders the support force to cease or shift supporting fires. Colored smoke grenades or pyrotechnics may be used as a signal to shift fires.

## **DANGER**

**To avoid injury, wear a protective mask to avoid exposure to any concentration of HC smoke.**

(3) The assault force must wait until the support force has shifted weapons and ceased firing before it enters the room.

(4) Soldiers unload and clear their weapons after the unit consolidates and reorganizes.

(5) Squad leaders inspect weapons before the AAR.

f. **Individual MOUT Tasks or Skills Trained ([FM 90-10-1](#)).**

(1) ***Clear a building.*** This requires the following tasks or skills:

- Clear a room.
- Vary clearing techniques.
- Reorganize after clearing a building.

(2) ***Select hasty firing positions in urban terrain.*** This requires the following tasks or skills:

- Fire around a building or wall.
- Fire from a window.
- Fire from unprepared loopholes.

(3) ***Enter a building.*** This requires the following tasks or skills:

- Select building entry points.
- Enter a building.

- Select use of hand grenades.
- Clear the entry point.

(4) ***Move in urban terrain.*** This requires the following tasks or skills:

- Follow rules of movement.
- Move across open areas.
- Move parallel to building.
- Cross obstacles.

(5) ***MOUT collective training tasks.*** The following T&EOs should be used ([ARTEP 7-8-MTP](#)):

- 7-3/4-1110, Clear a Building.
- 7-3/4-1118, Defend MOUT/Building.
- 7-3/4-1134, Move Tactically.

g. **Support Requirements.** Minimum materials required to train at this station include the following:

- (1) Materials to mark cleared rooms or buildings (chalk, cloth, paint, chemical lights, engineer tape, and so on).
- (2) Training demolition charges.
- (3) Training grenades.
- (4) Smoke grenades.
- (5) MILES.
- (6) Simulator, booby trap, whistling (optional).
- (7) 5.56-mm blank ammunition, ball ammunition, or plastic ammunition and M2 bolt.

## **2-4. STATION 2: CLEARING TECHNIQUES BUILDING**

This station is used to train a dismounted rifle squad. Regardless of the size unit being trained, it should be organized into an assault team and a support team. ([FM 90-10-1](#), Appendix F provides more information.) Live fire *may be used* at this station (Figure 2-4).

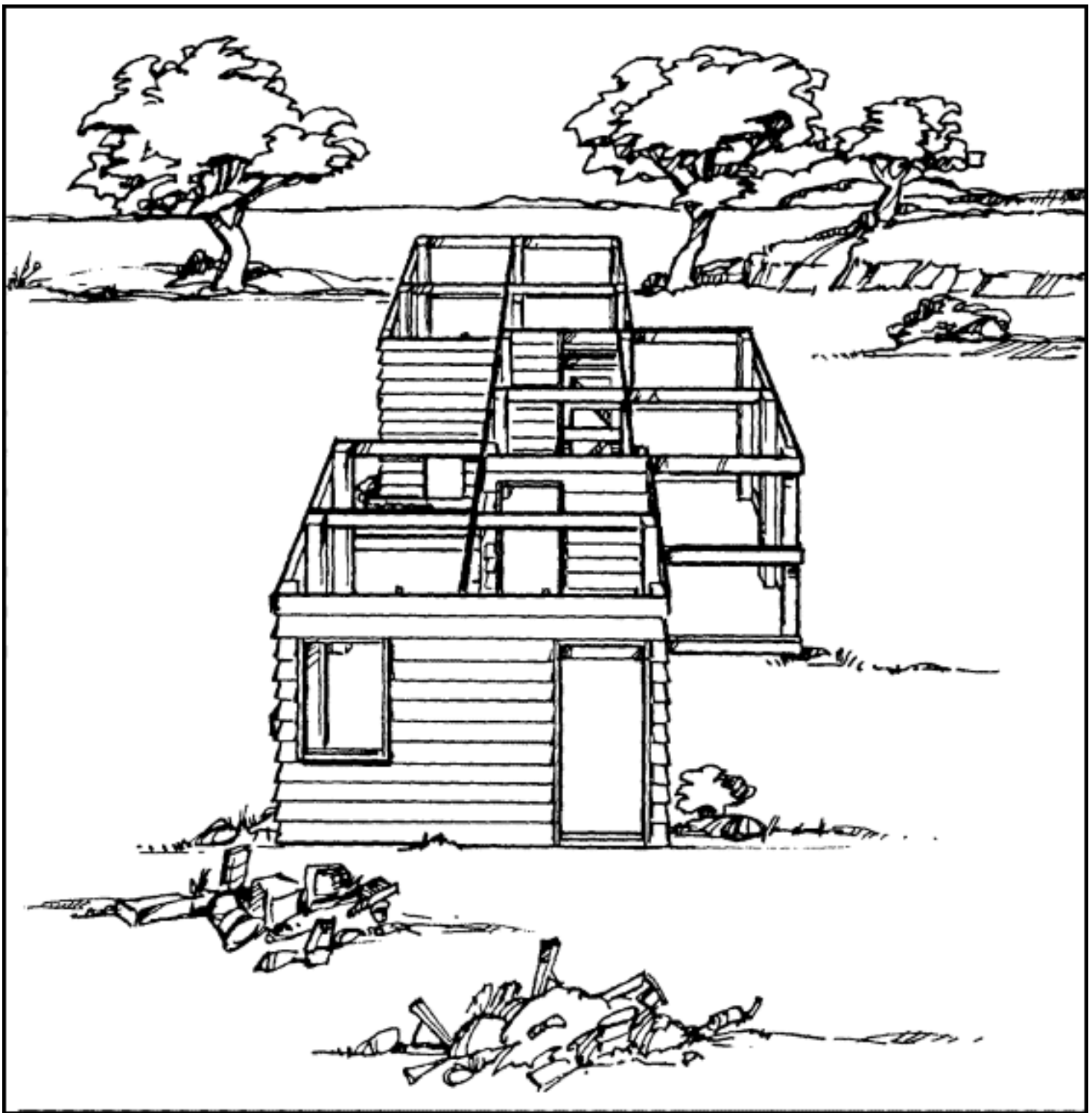

**Figure 2-4. Clearing techniques building.**

a. **Description.** This station has one structure with three adjoining rooms. The walls are either wood or target cloth. The first (nearest) room has a front window and a doorway; the second has a door and a side window; and the third has a blocked door and a mousehole. Cover is available at two locations forward of the near room and at one location in front of the mousehole.

b. **Targetry.** This station has three automated targets. One is in the doorway of the near room; another is in the far right corner of the middle room; and the last is in the far right corner of the far room (Figure 2-5). To reinforce caution during precision MOUT training, this station may be modified by changing target arrays.

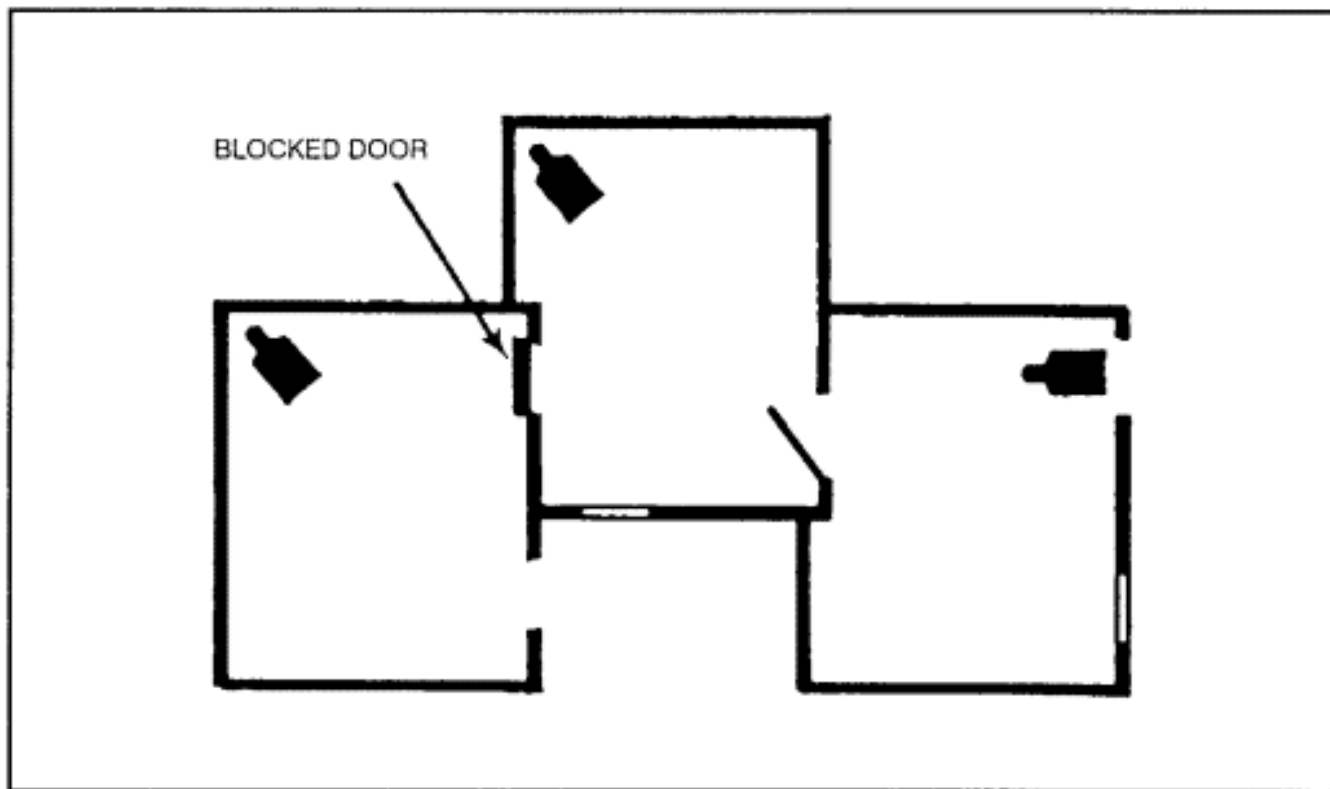

**Figure 2-5. Targetry, clearing technique building.**

c. **Purpose.** ([ARTEP 7-8-MTP](#), T&EO 7-3/4-1110 provides more information.) This station may be used to train soldiers to do the following:

- Clear a building.
- Vary the techniques of clearing rooms.
- Provide supporting fires.
- Coordinate clearing teams.
- Use smoke grenades.
- Clear booby traps.

d. **Controller Requirements.** The chief controller (usually the squad or platoon leader) has one assistant to operate targetry.

### **WARNING**

**To avoid injury, wear a protective mask to avoid exposure to any concentration of HC smoke.**

### **DANGER**

**To avoid injury or death, place your weapon on safe when climbing through obstacles such as windows, fences, and walls during training.**

e. **Safety Requirements.**

- (1) Only practice grenades are used on this range.
- (2) Soldiers unload and clear their weapons after the unit consolidates and reorganizes. Leaders check to ensure this is done.

f. **Individual MOUT Tasks or Skills Trained** ([FM 90-10-1](#)).

- (1) **Clear a building.** This requires the following tasks or skills:
  - Clear a room.
  - Vary clearing techniques.
  - Reorganize after clearing a room.
- (2) **Select hasty firing positions in urban terrain.** This requires the following tasks or skills:
  - Fire around a building or wall.
  - Fire from a window.
  - Fire from an unprepared loophole.
- (3) **Enter a building.** This requires the following tasks or skills:
  - Select point(s) to enter a building.
  - Enter a building.
  - Select use of hand grenades.
  - Clear the entry point.
  - Check for and clear booby traps.
- (4) **Move in urban terrain.** This requires the following tasks or skills:
  - Follow general rules of MOUT movement.
  - Move across an open area.
  - Cross obstacle.
- (5) **Collective training MOUT tasks.** T&EOs from ARTEP 7-8-MTP should be used.

g. **Applicable Leader Tasks.** Leaders check to ensure soldiers unload and clear their weapons after the unit consolidates and reorganizes.

h. **Support Requirements.** Minimum materials required to train at this station include the following:

- (1) Materials to mark cleared rooms or buildings (for example, chalk, cloth, tape).
- (2) Training grenades.
- (3) 5.56-mm blank ammunition, ball ammunition, or plastic ammunition and M2 bolt.
- (4) MILES (optional).
- (5) Training demolition charges.
- (6) Smoke grenades.

## 2-5. STATION 3: GRENADE GUNNERY

This station is used to train a dismounted infantry squad. Live fire *may be used* at this station (Figure 2-6).

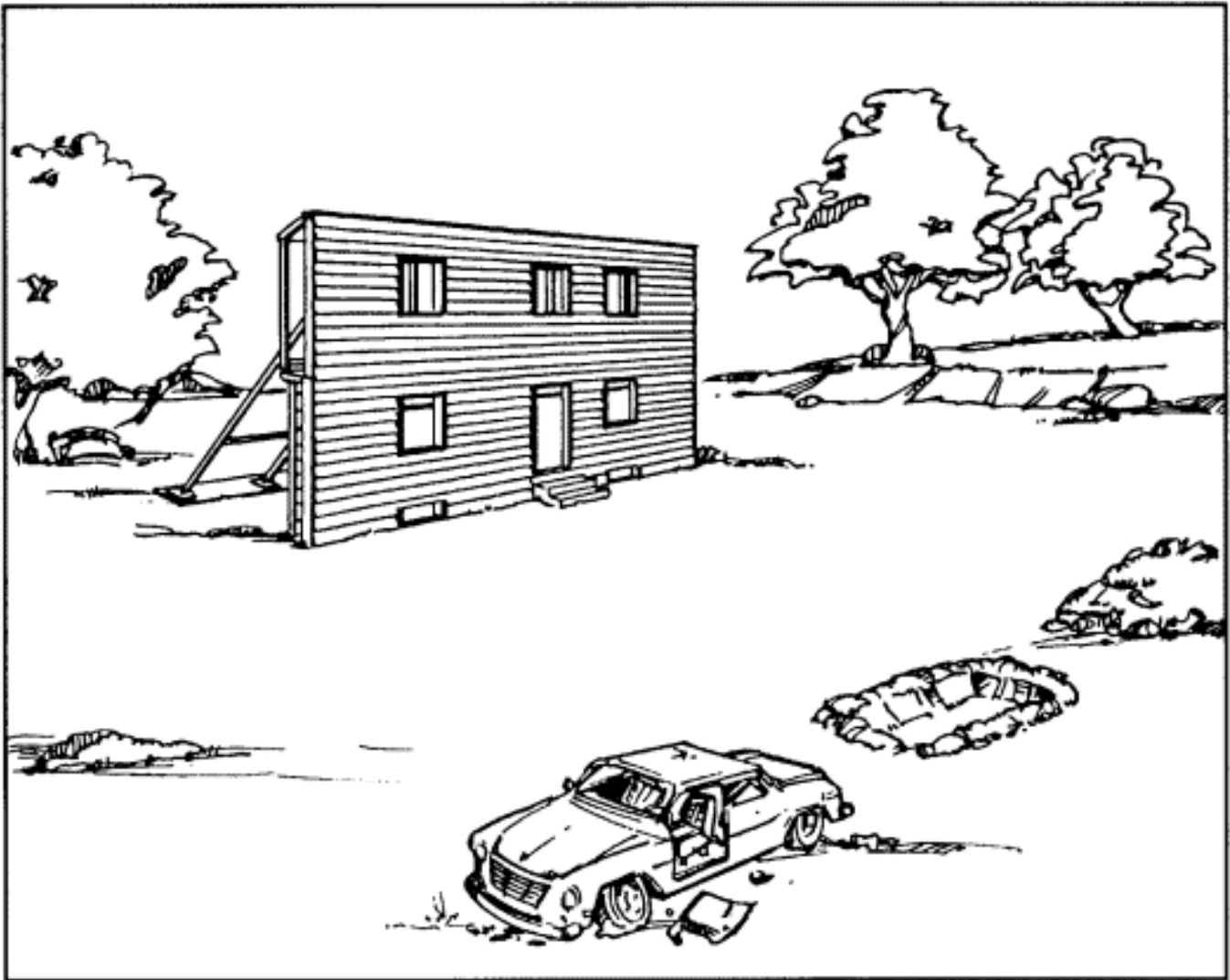

**Figure 2-6. Grenadier gunnery station.**

a. **Description.** This station has two main parts:

(1) The first part is a wooden facade that looks like one wall of a two-story building. This facade is about 20 feet high by 30 feet wide. It has three upper floor windows and two lower floor windows, a doorway with outside steps, and two basement windows at ground level.

(2) The second part consists of three firing positions located about 80 meters to the front of the facade. These positions have cover such as a wrecked car, a trench, rubble, or another facade with a window. Firing points should be adjusted in range to support precision or surgical training and to give soldiers confidence in first-round hits.

(3) Soldiers should never engage at ranges less than 31 meters, which is the minimum safe range. Trainers should ensure the station accommodates this requirement as well as the 14-meter arming range and the 160-meter maximum effective range (point targets).

b. **Targetry.** This station has three automated silhouette targets, located in the two windows and doorway of the first floor. The remaining windows, both upper floor and basement, have solid backdrops that permit concussion of the 40-mm TP round (Figure 2-7).

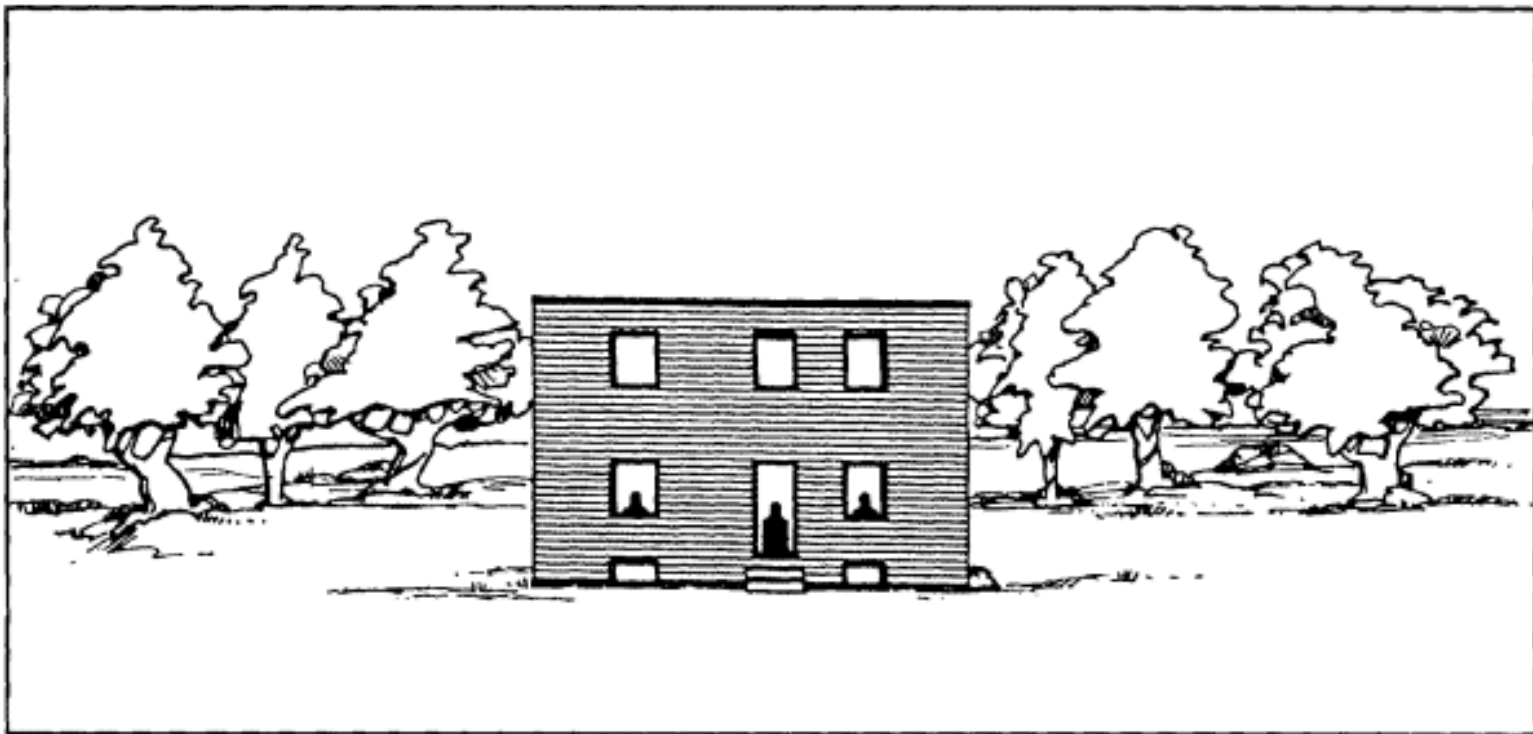

**Figure 2-7. Targetry, grenadier gunnery station.**

c. **Purpose.** This station may be used to train soldiers to provide supporting fires with the M16 rifle and with the M203 grenade launcher.

d. **Controller Requirements.** The chief controller (usually a squad or platoon leader) has one assistant to operate targetry.

e. **Safety Requirements.**

- (1) Grenadiers must consider head winds of 5 MPH or more when determining range and probable strike of rounds to prevent the rounds from impacting short of the target.
- (2) Grenadiers must ensure the M203 has overhead clearance.
- (3) All weapons must be unloaded and cleared before they are removed from the firing position.

f. **Individual MOUT Tasks or Skills Trained.** [FM 90-10-1](#) provides more information about individual MOUT tasks.

- (1) **Select hasty firing positions in urban terrain.** This requires soldiers to fire around a building or wall.
- (2) **Move in urban terrain.** This requires the following tasks or skills:
  - Follow general rules of movement.
  - Observe around corners.
  - Move across an open area.

g. **Applicable Leader Tasks.** [ARTEP 7-8-MTP](#), Chapter 2 provides more information about leader tasks and MOUT-specific skills.

h. **Support Requirements.** Minimum materials required at this station include the following:

- (1) TP 40-mm grenades (HE grenades are not allowed).
- (2) Smoke grenades.
- (3) 5.56-mm blank ammunition, ball ammunition, or plastic ammunition and M2 bolt.
- (4) MILES (optional).

## 2-6. STATION 4: DESTINY DOORWAY

This station is used to train a dismounted infantry squad, but may be modified to meet the training needs of specific units. Live fire *may be used* at this station (Figure 2-8).

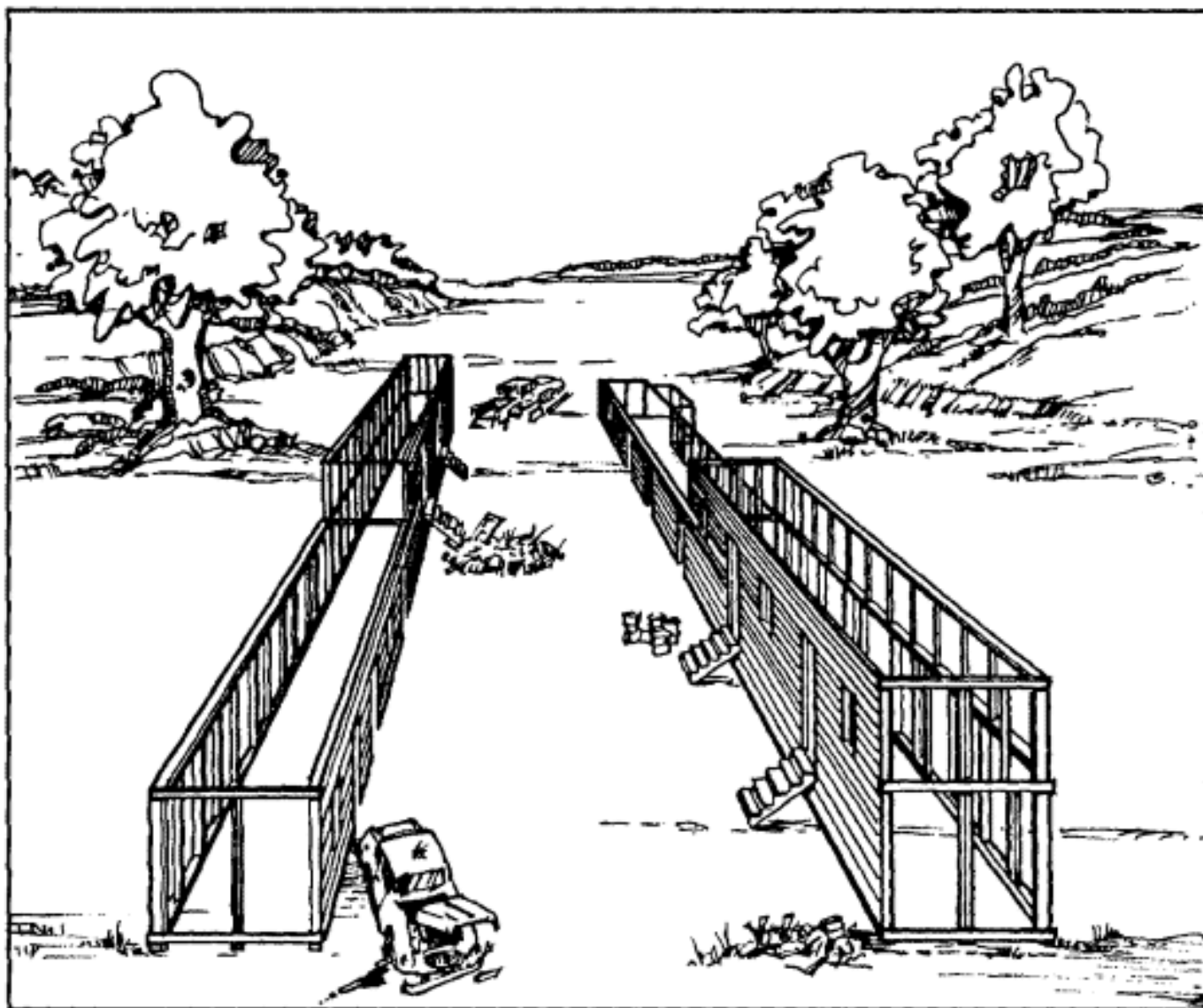

Figure 2-8. Destiny doorway station.

a. **Description.** This station has two separate, similar facades that face each other to recreate an urban street setting:

- (1) The right facade looks like a row of buildings along a street. This facade is made of wood and has many windows, doorways, stairways, and loopholes. A side wall is located at the near end. At the far end of the facade is an adjoining room made of target cloth.
- (2) The left facade is a mirror image of the right facade. It also has a side wall at the near end.

However, it has no adjoining room at the far end. Cover is available along the street at various locations.

b. **Targetry.** This station has two automated targets, located in the end room of the right facade. One target is in the doorway; the other is in the corner of the room (Figure 2-9).

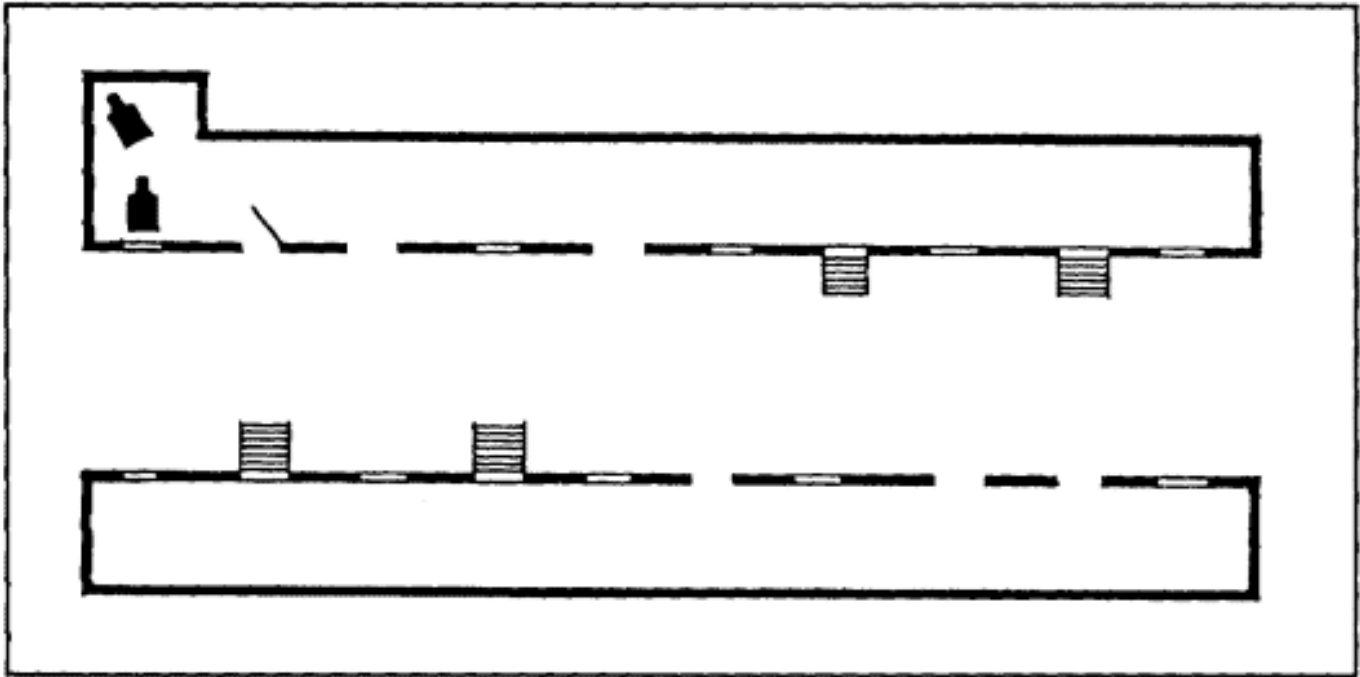

**Figure 2-9. Targetry, destiny doorway station.**

c. **Purpose.** This station may be used to train soldiers for several tasks. Trainers can develop their POI to practice movement and control of combat vehicles while operating with dismounted infantry personnel. Tasks that can be trained at this station include the following:

- Move down a street.
- Cross an open area.
- Rapidly engage targets of opportunity.
- Clear a room.
- Identify targets as friendly or enemy in a precision environment.

d. **Controller Requirements.** The chief controller has one assistant to operate the targetry. More controllers may be needed, if combat vehicles are employed.

e. **Safety Requirements.**

- (1) Only practice grenades are used on this range.
- (2) Soldiers unload and clear their weapons after the unit consolidates and reorganizes.

f. **Individual MOUT Tasks or Skills Trained.**

(1) **Clear a building.** This requires the following tasks or skills:

- Clear a room.
- Reorganize after clearing a room.

(2) **Select hasty firing positions in urban terrain.** This requires soldiers to fire around a building or wall.

(3) **Enter a building.** This requires the following tasks or skills:

- Select point(s) to enter a building.
- Enter a building.
- Select use of hand grenade.
- Clear the entry point.

(4) **Move on urban terrain.** This requires the following tasks or skills:

- Follow general rules of movement.
- Observe around corners.
- Move across open area.
- Move parallel to buildings.

g. **Support Requirements.** Minimum materials required to train at this station include the following:

(1) Materials to mark cleared rooms or building (for example, chalk, cloth, engineer tape, paint, chemical lights).

(2) Training grenades.

(3) Smoke grenades.

(4) 5.56-mm blank ammunition, ball ammunition, or plastic ammunition and M2 bolt.

(5) MILES (optional).

(6) Simulator, booby trap, whistling (optional).

## 2-7. STATION 5: DODGE CITY

This station is used to train a dismounted infantry squad but may be modified to meet the training needs of specific units. Live rifle ammunition and practice grenades *may be used* at this station (Figure 2-10).

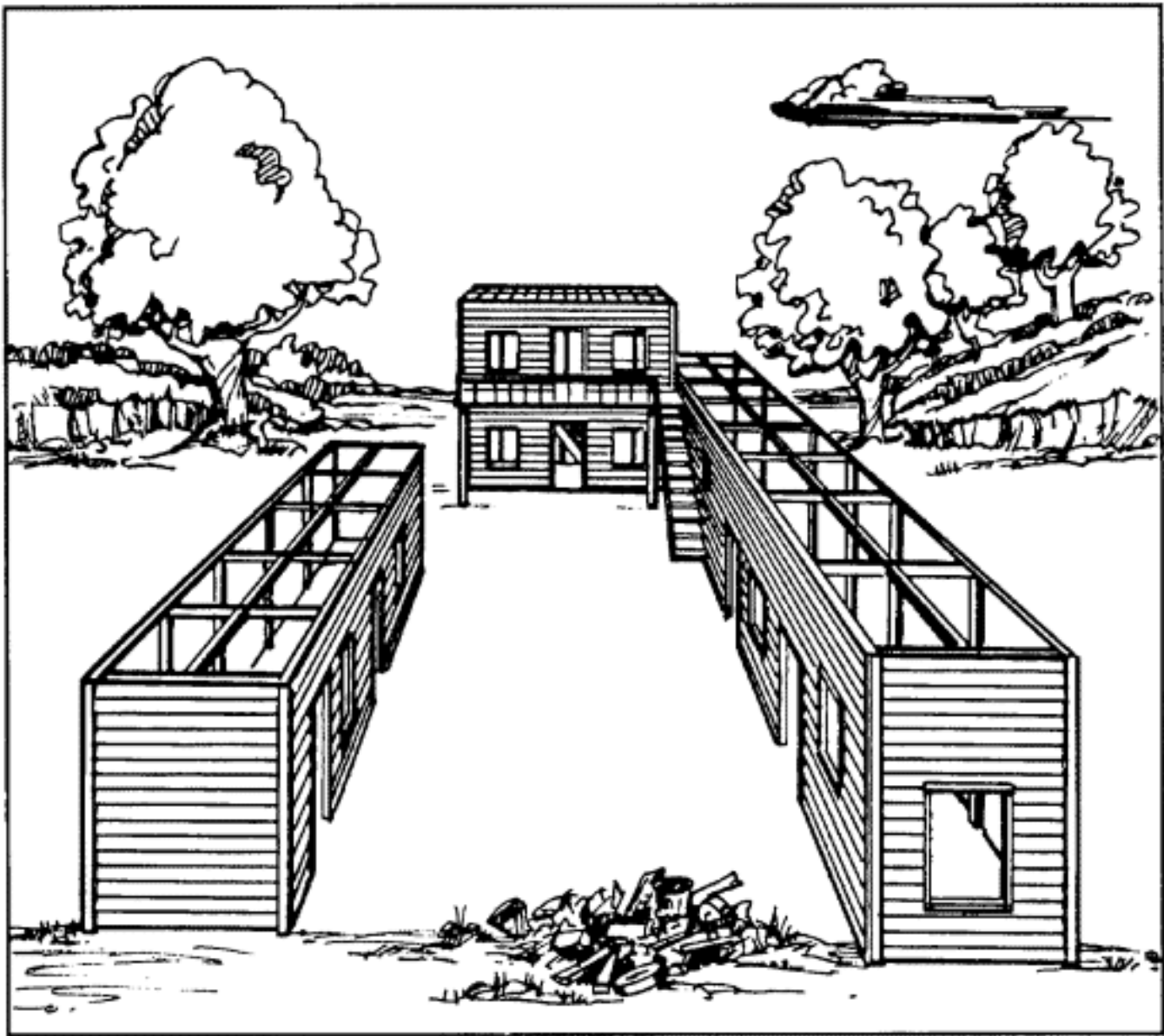

**Figure 2-10. Dodge City station.**

a. **Description.** This station has two facades. Each has two sides of wood and two of target cloth.

(1) One structure is an L-shaped facade. The long leg of the L to the right looks like a single-story building; the short leg to the front is a two-story structure. A landing is located along the length of the second floor with outside stairs leading down. An inside stairway also joins the floors. The two legs of the L are adjacent, with no access between them to their interiors. Cover is located at the end of the street opposite the two-story structure.

(2) The other structure is a facade located to the left of the other. It has a single floor and two rooms; each room has a window and a doorway. An open area much like a street separates this facade from the first.

b. **Targetry.** This station has seven automated targets. Five are in the two-story structure: four in the windows and one behind the first floor. The sixth is at the far end of the long side of the right structure. The seventh is in the corner of the far room of the left structure (Figure 2-11).

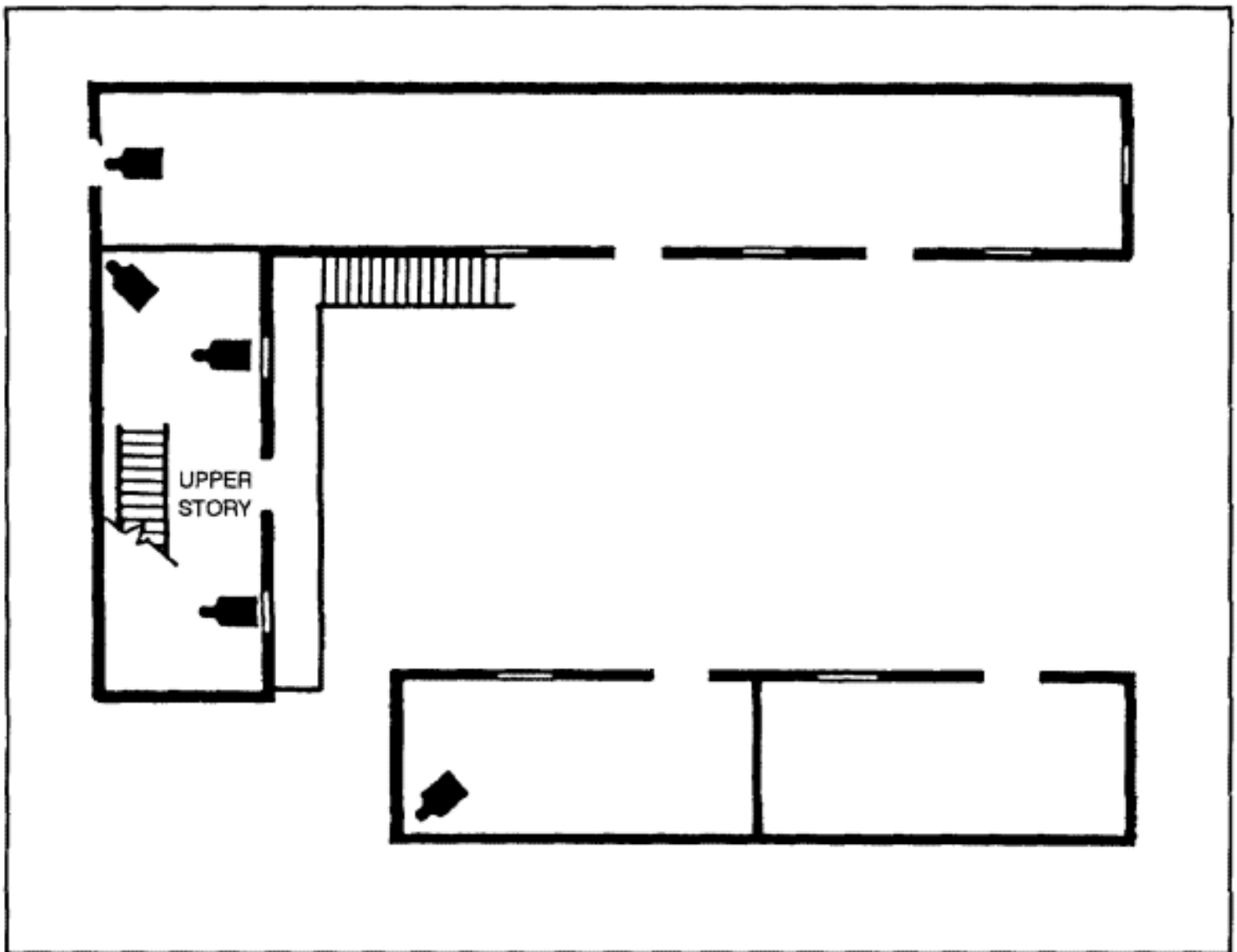

**Figure 2-11. Targetry, Dodge City station.**

c. **Purpose.** This station may be used to train soldiers to do the following:

- (1) Enter and clear a building.
- (2) Provide fire support.
- (3) Use smoke grenades.
- (4) Clear a street.

d. **Safety Requirements.**

- (1) Soldiers must know the location of other soldiers during this exercise.
- (2) Soldiers must be especially careful when moving with loaded weapons up or down stairs.
- (3) All weapons must be unloaded and cleared, after the unit consolidates and reorganizes.
- (4) Leaders must inspect all weapons before the AAR.

**DANGER**

**When you are on a lower floor, do not point your weapon upward as this endangers soldiers on the second floor.**

**e. Individual MOUT Tasks or Skills Trained.**

- (1) ***Clear a building.*** This requires the following tasks or skills:
  - Clear a room.
  - Vary clearing techniques.
  - Move between floors.
  - Reorganize after clearing a building.
- (2) ***Select hasty firing positions in urban terrain.*** This requires the following tasks or skills:
  - Fire around a building or wall.
  - Fire from a window.
- (3) ***Enter a building.*** This requires the following tasks or skills:
  - Select point(s) to enter a building.
  - Enter a building.
  - Select use of hand grenades.
  - Clear the entry point.
- (4) ***Move in urban terrain.*** This requires the following tasks or skills:
  - Follow general rules of movement.
  - Move across open area.
  - Move parallel to building.
  - Cross obstacle.

**f. Support Requirements.** Minimum materials required to train at this station include the following:

- (1) Materials to mark cleared rooms or buildings (for example, chalk, cloth, engineer tape, paint, chemical lights).
- (2) Training hand grenades.
- (3) Smoke grenades.
- (4) 5.56-mm blank ammunition, ball ammunition, or plastic ammunition and M2 bolt.
- (5) MILES (optional).

**2-8. STATION 6: GRENADE HOUSE**

This station is used to train dismounted fire teams and squads. Live fire, including fragmentation hand grenades, *may be used* at this station (Figure 2-12).

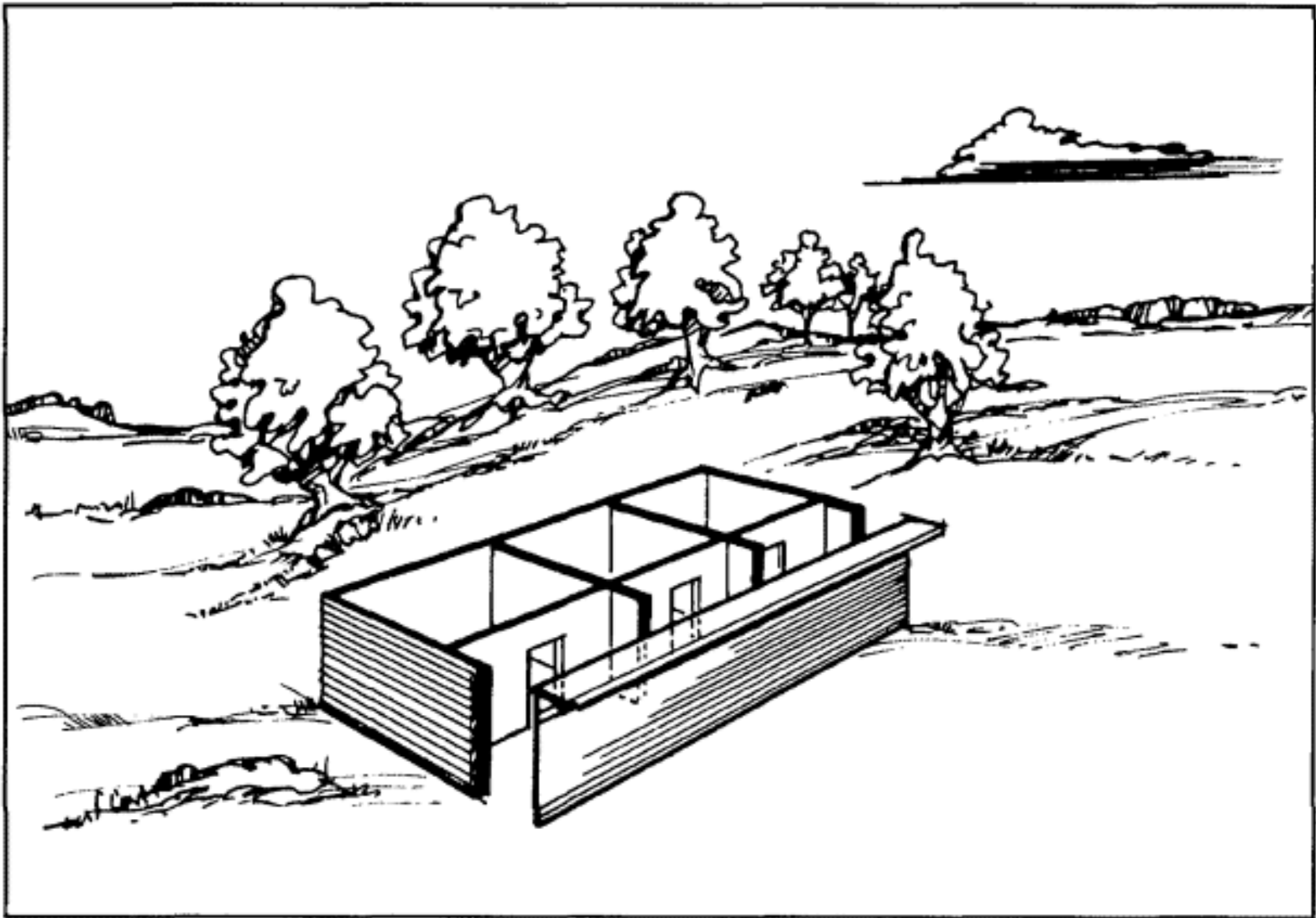

**Figure 2-12. Grenade house.**

a. **Description.** This station has one structure. This structure has three separate rooms along a single hallway; each room has an open doorway. The concrete interior walls are designed to absorb bullets and grenade fragments.

### **CAUTION**

**Do not try to replace the wall panels in the grenade house before consulting with engineers about the concrete mixture required.**

b. **Targetry.** This station has no automated targetry. However, E-type silhouettes can be used or targets can be painted on the walls inside the room.

c. **Purpose.** This station may be used to train soldiers to enter and clear a room using live small-arms ammunition and fragmentation grenades in a realistic environment.

d. **Controller Requirements.** The chief controller has one assistant who acts as safety NCO and accompanies each team as it clears.

e. **Safety Requirements.**

## DANGER

**Never cook off *live* grenades in training. Doing so could injure or kill you. You may cook off practice grenades, but only with adequate training and supervision.**

- (1) Soldiers should wear hearing protection IAW local hearing conservation directives and range safety SOPS.
- (2) Soldiers should wear extra protection IAW local range safety directives. Use of body armor and eye protection goggles is recommended.
- (3) Soldiers must remain close to the wall during grenade detonation to avoid any shrapnel that might exit the open doorway.
- (4) Trainers should minimize dust in the rooms to ensure that soldiers in the clearing rooms can see each other. They can wet down the floors and treat the rooms with a dust retardant.
- (5) Soldiers unload and clear their weapons after the unit consolidates and reorganizes.
- (6) Leaders inspect weapons before the AAR.

### f. Individual MOUT Tasks or Skills Trained.

- (1) ***Clear a building.*** This requires the following tasks or skills:
  - Clear a room.
  - Move along a hallway.
  - Reorganize after clearing a building.
- (2) ***Select hasty firing positions in urban terrain.*** This requires soldiers to fire around a building or wall.
- (3) ***Move in urban terrain.*** This requires the following tasks or skills:
  - Follow general rules of movement.
  - Move parallel to a building.

### g. Support Requirements. Minimum materials required to train at this station include the following:

- (1) Materials to mark rooms (chalk or engineer tape).
- (2) Service hand grenades.
- (3) 5.56-mm blank ammunition, ball ammunition, or plastic ammunition and M2 bolt.
- (4) MILES (options).

## 2-9. STATION 7: URBAN DEFENSE

This station is used to train two to three dismounted infantry squads simultaneously at its three separate substations. These substations include upper floor entrance techniques, prepare defense, and basement counterattack. Live fire *may not be used* at this station (Figure 2-13).

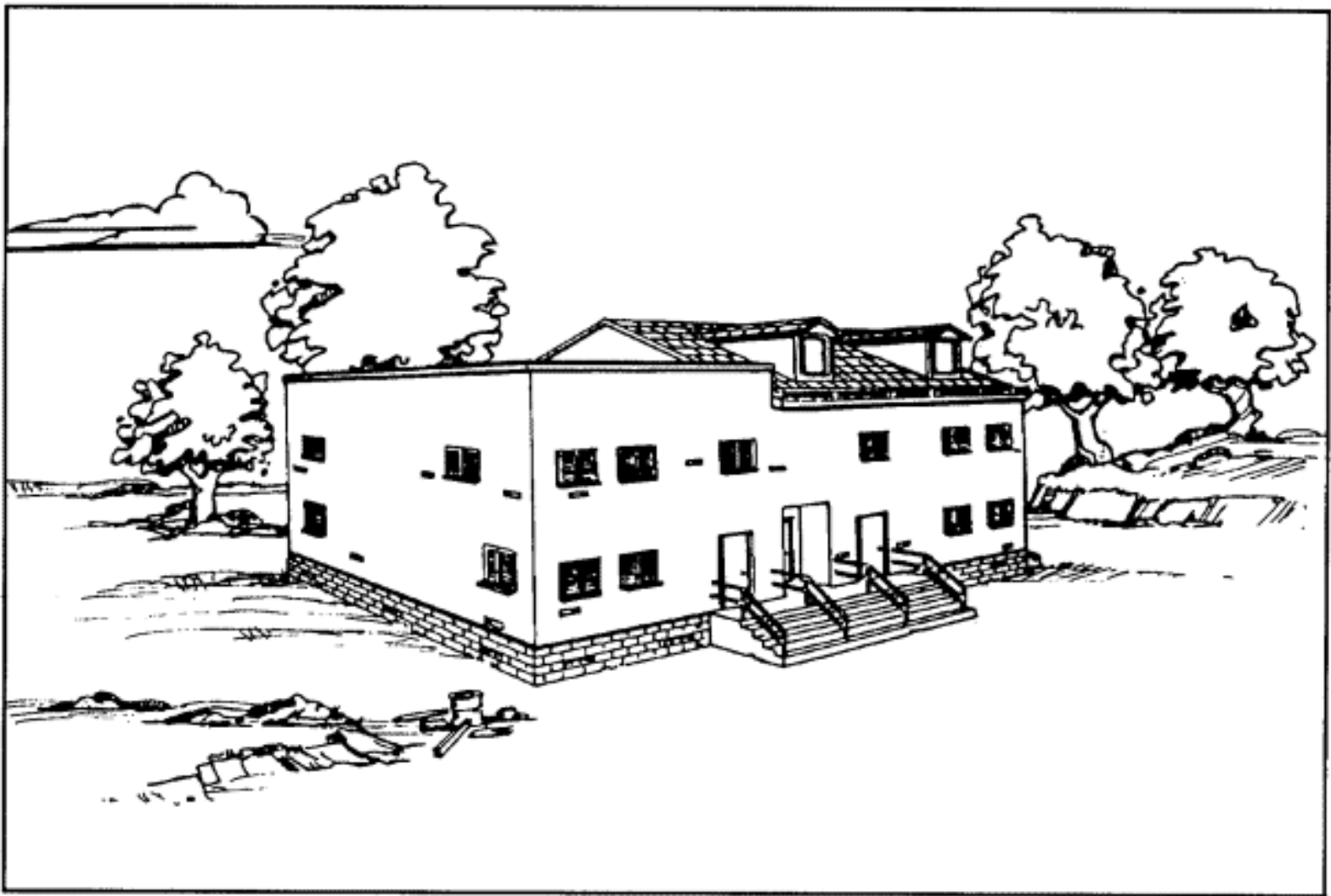
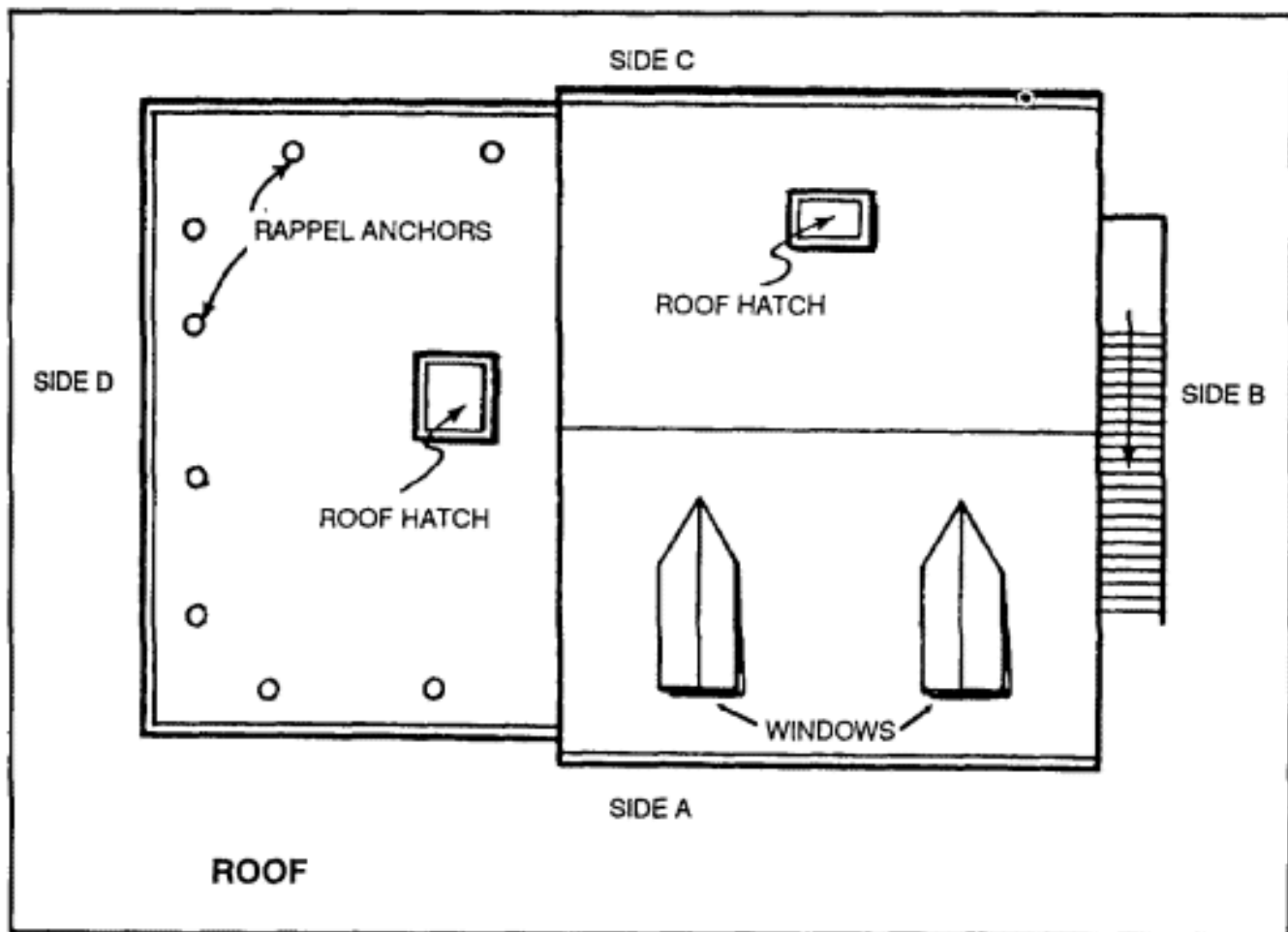

**Figure 2-13. Urban defense station.**

- a. **Description.** This station is a heavily constructed, two-story building with a basement. Each floor has several rooms with many windows, doorways, loopholes, and mouseholes. The gabled roof has windows and a hatch to the attic below. Half of the rooftop is flat. The building has exterior stairways.
- b. **Targetry.** This station has two automated targets, two MILES targets, or both, in the basement rooms.

## **2-10. SUBSTATION 7A: UPPER-FLOOR ENTRY TECHNIQUES**

This is one of three substations in the urban defense station. This substation is used to train two sections. One unit conducts rappelling training from the roof, while the other practices using grappling hooks to enter through a second-story window. After completing their respective training sequences, the units may switch tasks. Live fire *may not be used* at this substation (Figure 2-14).



**Figure 2-14. Upper-floor entry techniques.**

- a. **Description.** This substation includes the roof of the two-story urban defense station building. Half of the rooftop is flat, the other half is gabled. The gabled part of the roof has windows and a hatch to the attic below. The building has exterior stairways.
- b. **Purpose.** This substation may be used to train soldiers to enter a building from the roof either by rappelling or using a grappling hook.
- c. **Controller Requirements.** The chief controller supervises a roof NCO and a ground safety NCO. To support concurrent training, one squad leader may act as the controller on the roof and another may act as controller on the ground.
- d. **Rappelling.** The following applies to the unit entering the building by rappelling from the roof to a window below:
- (1) **Safety requirements (rappelling).**
    - (a) Leaders must know safety requirements in TC 90-6-1 and safety SOPs.
    - (b) Leaders ensure that the point of the ledge from which each soldier rappels is not slippery.
    - (c) Leaders verify that the rappel rope is securely tied to the anchor point.
    - (d) Soldiers must know the rappelling techniques they are required to use.

(e) A controller at ground level should serve as the belay soldier for safety purposes.

(f) Soldiers must wear gloves to protect their palms from severe rope burns.

(2) ***Individual MOUT tasks or skills trained (rappelling).***

(a) *Clear a room or building.* This requires soldiers to clear a room.

(b) *Select hasty firing positions in urban terrain.* This requires the following tasks or skills:

- Fire around a building or wall.
- Fire from a window.

(c) *Enter a building.* This requires the following tasks or skills:

- Select point(s) to enter a building.
- Select use of hand grenades.
- Clear the entry point.

(d) *Move in urban terrain.* This requires the following tasks or skills:

- Follow general rules of engagement.
- Observe around a corner.
- Move parallel to buildings.

(3) ***Support requirements (rappelling).*** Minimum materials required to train at this station include the following:

(a) 120-foot climbing ropes.

(b) 13-foot sling ropes.

(c) Materials to mark cleared rooms or buildings (for example, chalk, cloth, engineer tape, and other suitable materials).

(d) Snap links.

(e) Work gloves.

(f) 5.56-mm blank ammunition.

e. **Using Grappling Hook.** The following applies to the unit using a grappling hook to enter the second-story window of a building:

(1) ***Safety requirements (grappling hook).***

(a) Soldiers and controllers must ensure the grappling hook is securely in place before the soldiers try to climb.

(b) Soldiers must be careful when tossing the grappling hook in case they miss the window and the hook falls to the ground.

(2) ***Individual MOUT tasks or MOUT skills trained (grappling hook).*** The preferred method for clearing a building is from the top down. Based on the building design, suitable grappling

hooks and ropes must be selected. Since most of these tasks are likely to be performed in smoke, units should not consider soldiers "trained" until they perform the task wearing a protective mask. Using a grappling hook to enter a window is difficult and requires training and upper-body strength. [FM 90-10-1](#), Chapter 5 highlights the following key teaching points or techniques:

- (a) Knot the rope at 1-foot intervals to simplify climbing.
- (b) Pull the hook to a window corner for a better "bite" and to reduce exposure from other windows.
- (c) Stand close to the wall when throwing the hook. This reduces exposure and limits the distance for the hook to travel.
- (d) Use smoke, if necessary, to reduce exposure while climbing.
- (e) Avoid silhouetting soldiers in windows of uncleared rooms.
- (f) Climb with weapon slung over the firing shoulder to quickly bring it to a firing position.
- (g) Clear rooms with grenades before entering. (Throwing a grenade while hanging from a rope requires training.)
- (h) Enter windows by placing one leg over the window sill first, then entering sideways, straddling and keeping the torso in contact with the ledge.

(3) **Support requirements (grappling hook).** Minimum materials required to train at this station include the following:

- (a) Grappling hook with rope.
- (b) Material to mark cleared rooms or buildings (for example, chalk, cloth, or engineer tape).
- (c) 5.56-mm blank ammunition.

## 2-11. SUBSTATION 7B: PREPARED DEFENSE

This is one of three substations in the urban defense station. This substation is used to train a dismounted squad or platoon. Live fire *may not be used* at this substation.

- a. **Description.** This substation is part of the urban defense station. Each floor has several rooms with many windows, doorways, loopholes, and mouseholes. The gabled roof has windows and a hatch to the attic below. Half of the rooftop is flat. The building has exterior stairways.
- b. **Purpose.** This substation may be used to train soldiers to plan a defense and to construct defensive positions.
- c. **Controller Requirements.** The platoon leader may act as the controller, while one or two squads attack the defending squad.
- d. **Safety Requirements.**

- (1) Soldiers and leaders must ensure fighting positions are sturdy and will not collapse on the soldier.
- (2) Soldiers should wear protective gloves when handling concertina wire.
- (3) Leaders and trainers must ensure that the number of sandbags used to construct positions is within the building's load-bearing capabilities.

### **WARNING**

**To avoid inflicting carbon burns or more serious injury, never fire blank ammunition at other soldiers within 1 meter.**

#### e. **Individual MOUT Tasks or Skills Trained** ([FM 90-10-1](#)).

- (1) **Select hasty firing position in urban terrain.** This requires the following tasks or skills:
  - Fire from a window.
  - Fire from an unprepared loophole.
- (2) **Prepare individual rifle positions and crew-served antitank weapons positions in urban terrain.** This requires the following tasks or skills:
  - Prepare individual rifle position.
  - Prepare crew-served antitank weapons position.
- (3) **Camouflage.**
- (4) **Use shadows.**
- (5) **Emplace obstacles.**

f. **Leader and Collective Training.** Trainers can develop their POI to practice some or all of the leader and collective tasks associated with "Secure and Defend a Unit Position" (07-2-C314). [FM 90-10-1](#) discusses some MOUT-specific topics associated with this task: in Chapter 4 (in the "time available" paragraph) it discusses the priorities of work and gives an example of the tasks that must be accomplished during the preparation phase. FM 90-10-1, Chapter 5, shows several designs and options for preparing positions. FM 90-10-1, Appendix C, discusses how to emplace obstacles, mines, and demolitions in streets, buildings, roofs, open spaces, dead spaces, and underground systems. FM 90-10-1, Appendix E, provides more details about the design of fighting positions and obstacles as well as about building modifications to support the defense.

#### g. **Support Requirements.** Minimum materials required to train at this station include the following:

- Training M72-series LAWs or M136 AT4s.
- Concertina wire.
- Sandbags (prefilled to save training time).
- Booby traps.
- Ladder.
- Lumber.

- Furniture.
- 55-gallon drums.
- Blankets.
- Water.
- Chalk, engineer tape, cloth strips (to mark routes and points for ammunition, casualties, and equipment).
- Work gloves.
- Climbing rope.
- MILES (optional).
- 5.56-mm blank ammunition.

## 2-12. SUBSTATION 7C: BASEMENT COUNTERATTACK

This is one of three substations in the urban defense station. This substation is used to train a dismounted infantry squad. Live fire *may not be used* at this substation.

- a. **Description.** This substation is part of the urban defense station building. Each floor has several rooms with many windows, doorways, loopholes, and mouseholes.
- b. **Purpose.** This substation may be used to train soldiers to clear a basement and to use a mousehole to move between floors.
- c. **Controller Requirements.** Only one controller is needed.
- d. **Individual MOUT Tasks or Skills Trained ([FM 90-10-1](#)).**
  - (1) **Enter a building.** This requires the following tasks or skills:
    - Clear the entry point.
    - Clear a room.
    - Select a hand grenade.
    - Move between floors.
    - Clear a basement.
    - Reorganize after clearing a building.
  - (2) **Select hasty firing position in urban terrain.** This requires soldiers to fire around a building or a wall.
  - (3) **Move in urban terrain.** This requires the following tasks or skills:
    - Follow general rules of movement.
    - Observe around corners.
    - Move parallel to buildings.
- e. **Support Requirements.** Minimum materials required to train at this station include the following:
  - Training hand grenades.
  - 5.56-mm blank ammunition.

- MILES (optional).
- Material to mark cleared rooms or buildings (for example, chalk, engineer tape, cloth).

## 2-13. STATION 8: UNDERGROUND TRAINER

This station is used to train a dismounted infantry squad. Live fire *may not be used* at this station; blank ammunition only can be used.

a. **Description.** This station is a sewer system built in a loop pattern, with a manhole at each turn in the loop. Two access tunnels lead from the outside at ground level to the underground loop.

(1) **Closed underground trainer.** The entire station is covered by a mound of earth. Only the manholes are exposed at the top of the mound; only the ground-level entrances to the access branches are exposed at the sides of the mound. Short, false extensions at each manhole simulate a large network of underground passages (Figure 2-15).

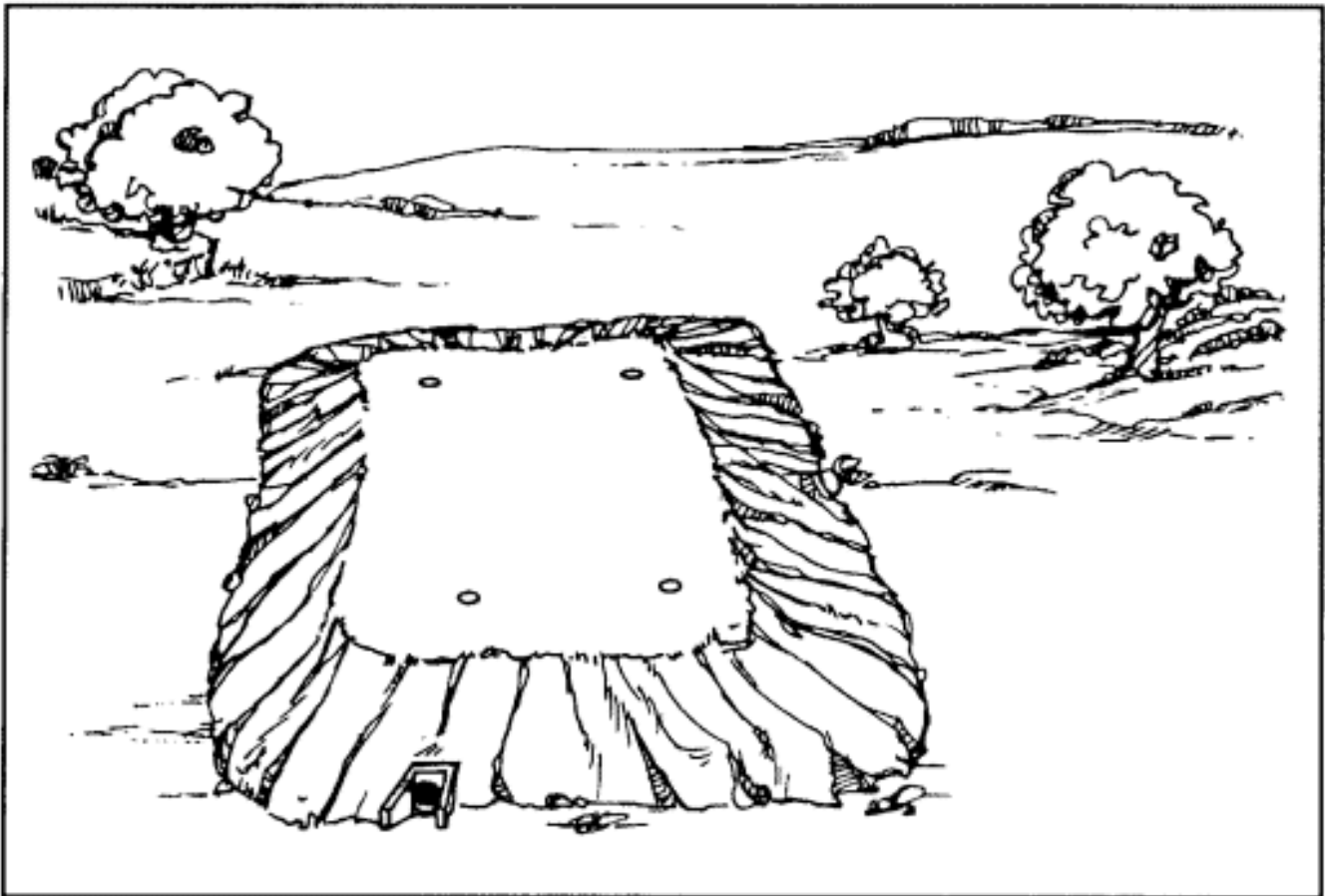

**Figure 2-15. Suggested design for closed underground trainer.**

(2) **Open underground trainer.** The alternative design for the enclosed underground trainer is an uncovered sewer system constructed with clear plastic tubes instead of steel or concrete tunnels (Figure 2-16). The dimension and size of the system are identical to those used for the closed underground trainer. Using clear tubes enables observers to see inside the open trainer; constructing berms on the sides of the tubes prevents them from observing intersecting tubes. Adding an observation tower in the center of the open trainer allows the training to be filmed for use during the AAR. If the unit is ready to train in darkness during daylight hours, tarpaulins can be used to cover the plastic tubing, blocking out light.

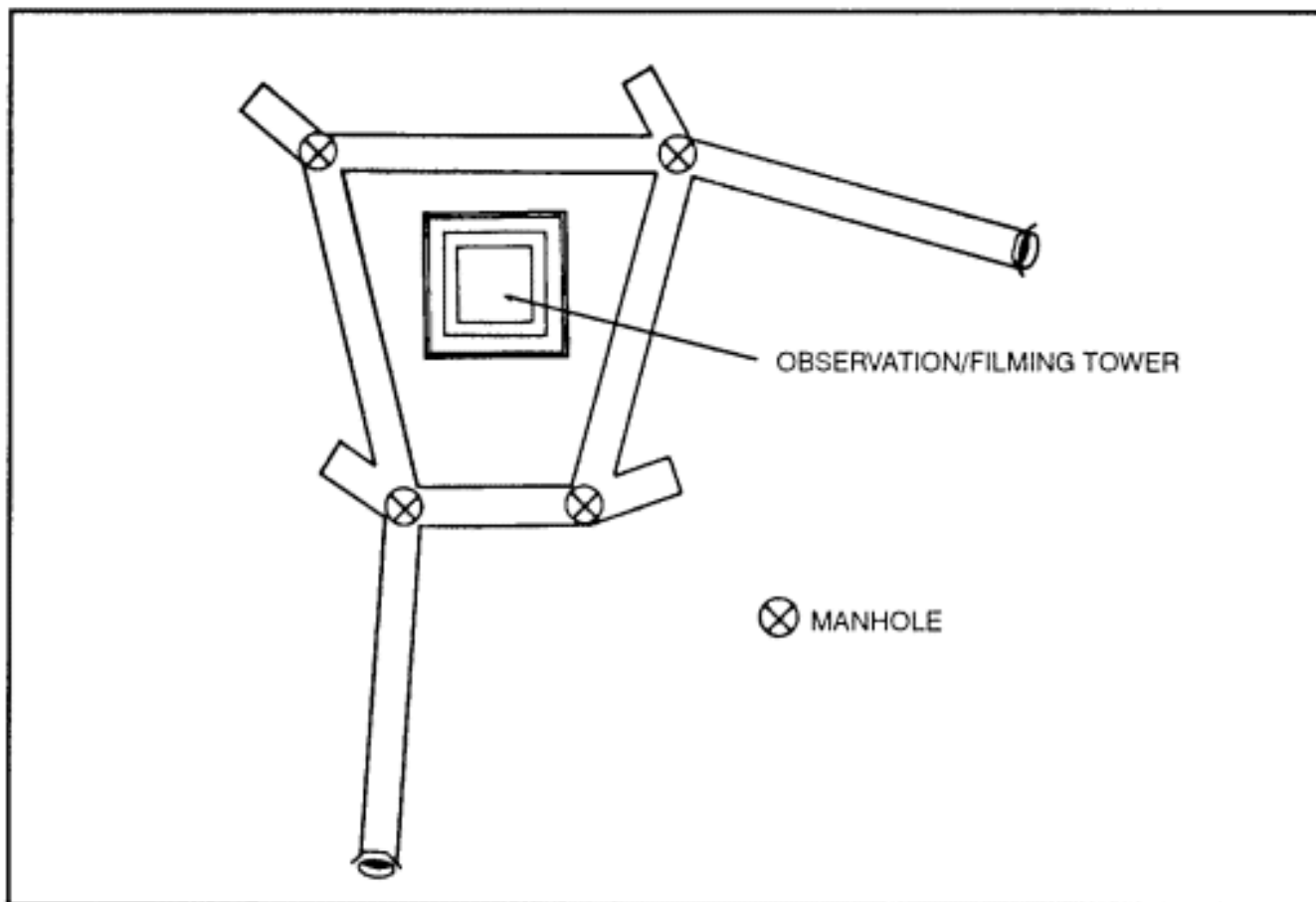

**Figure 2-16. Suggested design for open underground trainer.**

b. **Targetry.** This station has target silhouettes or OPFOR soldiers in OPFOR uniforms.

c. **Purpose.** This station may be used to train soldiers to do the following:

- Move in sewers.
- Clear a sewer of enemy soldiers.
- Block a sewer.

d. **Controller Requirements.** The controller may be either the platoon leader or one of the squad leaders.

e. **Safety Requirements.**

- (1) Soldiers should wear their helmets whenever they are in the sewer system to avoid head injuries.
- (2) Smoke grenades *will not be carried* into the underground trainer.

## DANGER

**To avoid asphyxiation when you are in the trainer, never detonate smoke grenades in the sewer. Using any type of the explosive simulator is extremely dangerous in an enclosed space.**

**The protective mask is not effective in oxygen-deficient atmospheres. *Never* enter any confined space where oxygen may have been displaced.**

f. **Individual MOUT Tasks or Skills Trained** ([FM 90-10-1](#)). T&EOs from [ARTEP 7-8-MTP](#) should be used for each of the following:

- Follow general rules of movement.
- Move across open area.

g. **Support Requirements.** Minimum materials required to train at this station include the following:

- Night vision goggles.
- Blank adapters.
- 5.56-mm blank ammunition.
- Sewer plan.
- Tools to open manhole cover.
- Telephone wire reel.
- Field telephones (two).
- Radio.
- Flashlights (each soldier).
- Chalk (each soldier).
- Chicken wire or screen.
- Earplugs (each soldier).
- Rucksack (for soldier assigned to demolitions).
- M203 grenade launcher.
- Protective masks (each soldier).
- Work gloves (each soldier).
- Safety rope, 120 feet long.
- Chemical alarm.
- Training mines (optional).
- Training booby traps.
- Signal operation instructions (SOI).
- MILES (optional).

## CHAPTER 3

# COLLECTIVE TRAINING FACILITY

*Squads, platoons, companies, and battalions can practice MOUT collective tasks at the collective training facility (CTF).*

### 3-1. DESCRIPTION

The CTF recreates a typical urban terrain. The facility includes buildings, roads, and other urban features. It consists of either 16 or 32 buildings. Appendix C provides a list of existing CTFS.

- a. Elements not training in the CTF can perform other missions in nearby training areas. For example, other elements of a battalion act as the reserve or establish a supporting battle position in adjacent natural terrain. Leaders can also use elements from their own units to make up the OPFOR for a force-on-force exercise.
- b. An accurate model of the CTF should be made available to trainers. The model should be constructed so trainers can disassemble it and view its interior. This model helps in leader training, classroom instruction, OPORD briefings, and AARs for the training exercise.
- c. The 16-building CTF has 9 intact and 7 partly destroyed buildings. The 32-building CTF has 16 of each. Both sizes of CTF have paved roads and parking areas, underground sewers, and other urban features (Table 3-1).

BUILDING TYPE	16-BUILDING CTF		32-BUILDING CTF	+
	INTACT	PARTLY DESTROYED	INTACT	PARTLY DESTROYED
HOTEL/CITY HALL	1	0	1	1
APARTMENT	1	0	1	2
OFFICE	1	1	2	1
BUSINESS/RESIDENTIAL	1	0	2	2
TOWNHOUSE	1	2	2	2
SCHOOL	1	0	1	1
RETAIL/BANK	1	0	1	1
VEHICLE/SERVICE STATION	0	1	1	1
WAREHOUSE	1	0	1	1
RESIDENTIAL	1	3	4	4
<b>SUBTOTAL</b>	<b>9</b>	<b>7</b>	<b>16</b>	<b>16</b>
<b>TOTAL</b>	<b>16</b>		<b>32</b>	

**Table 3-1. Building types.**

d. The buildings have one, two, or three stories. Some have basements, sloped roofs, or flat roofs. These building variations pose different tactical and technical problems, for example:

- (1) The hotel is a dominating structure typical of a central business district. It has an elevator

shaft, fire escapes, and a large first-floor lobby.

(2) The apartment building contains a series of identical rooms.

(3) The school has a long, central corridor, large windows, and a single large room.

(4) The townhouse has an attic that is common to two segregated parts of the building. Thus, the attic provides an important route from the top of one part to the top of the other.

(5) The service station accommodates combat vehicles in its service bay.

e. The buildings have other features that enhance the CTF's training value.

(1) Constructed mouseholes permit movement between rooms and floors.

(2) Loopholes in roofs and outside walls allow observation and fields of fire.

(3) Roof hatchways lead to the top floors of multistory buildings.

(4) Reinforced window ledges in upper-story windows permit the use of grappling hooks.

(5) Rooms vary in size and in the number of doorways and windows they have. These variations require soldiers to identify rooms that provide suitable indoor fighting positions for TOWs, Dragons, and LAWs. Partly destroyed buildings further enrich the tactical environment and pose additional challenges to leaders and soldiers. Figures 3-1 and 3-2 depict typical 16-building and 32-building CTFS.

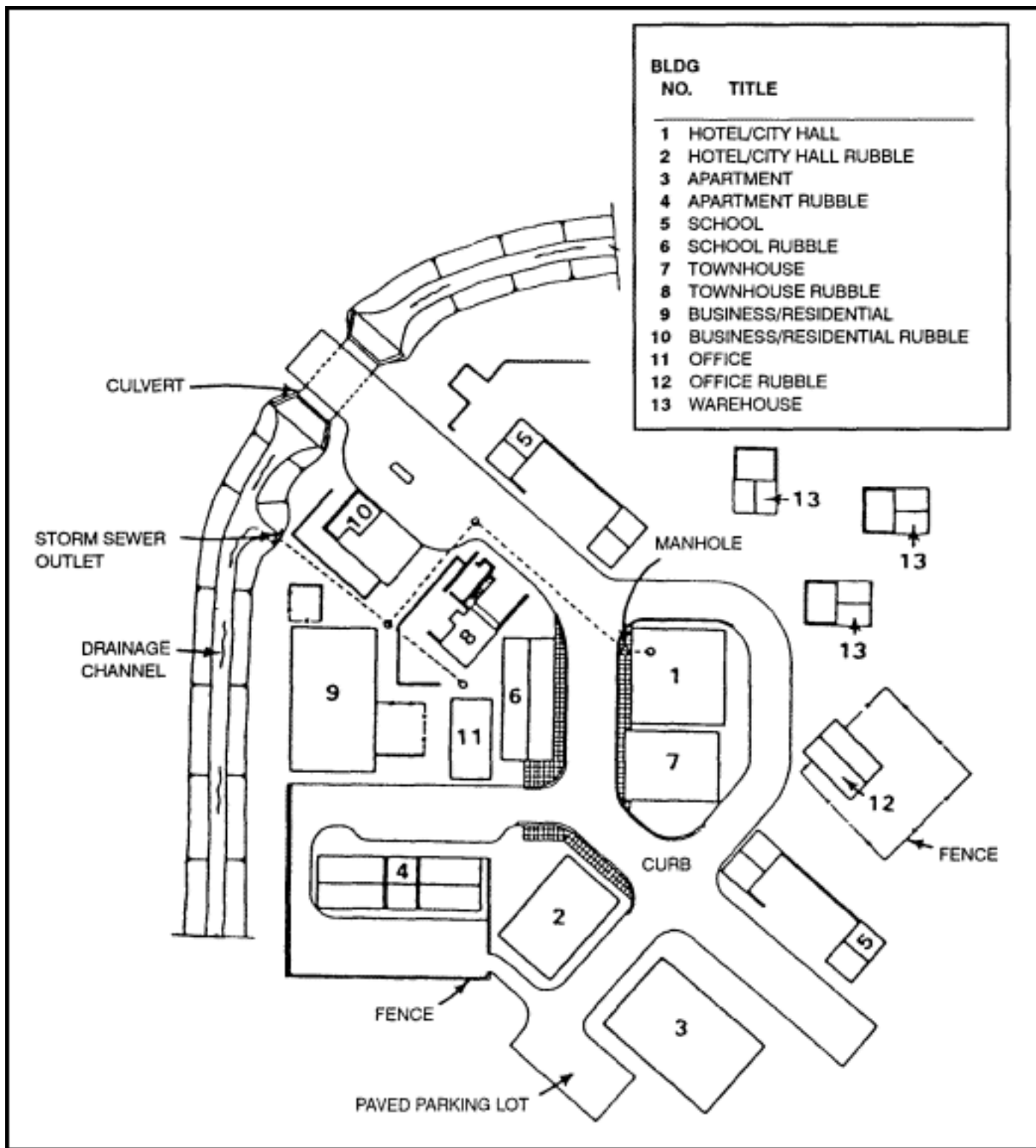
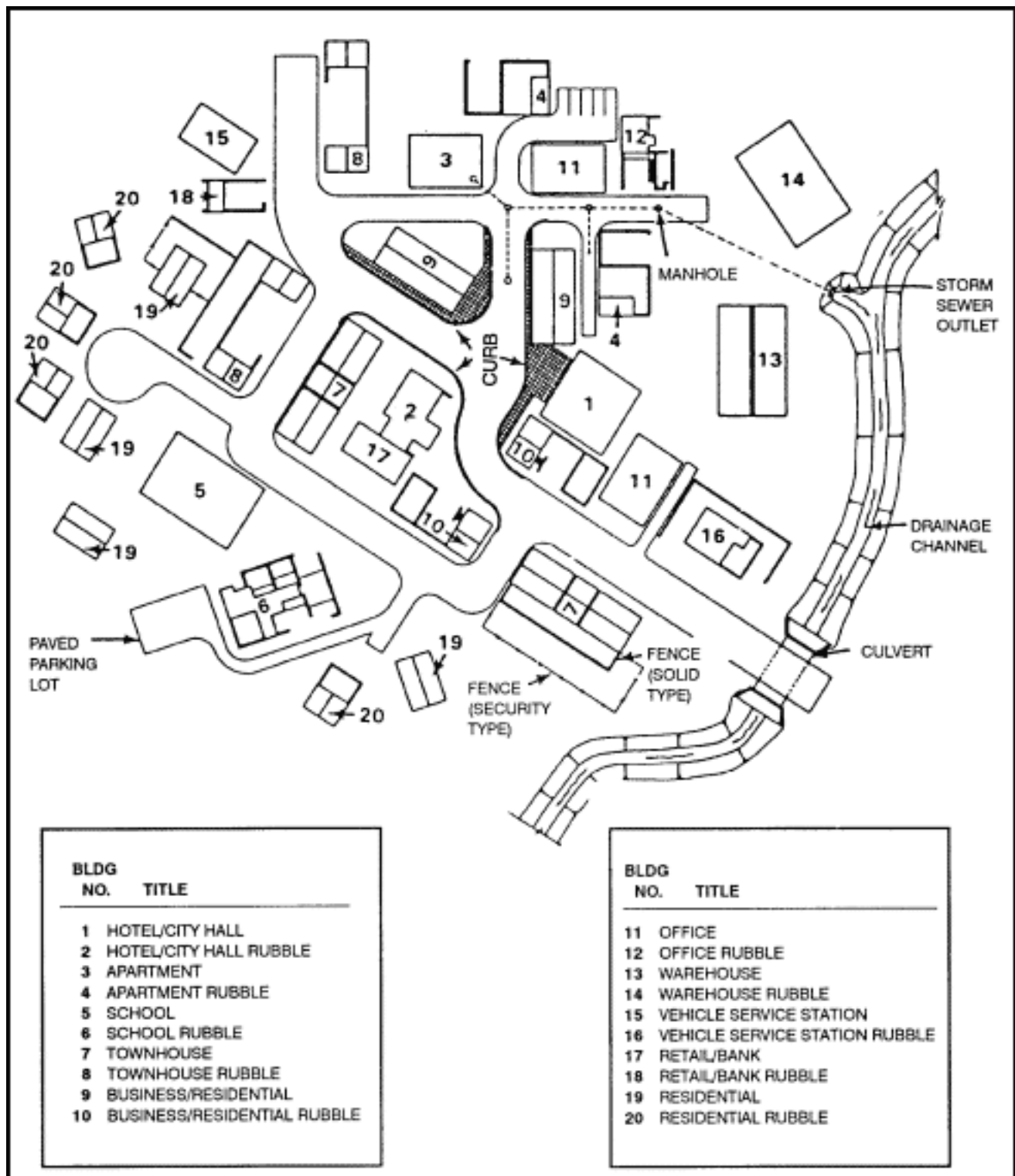
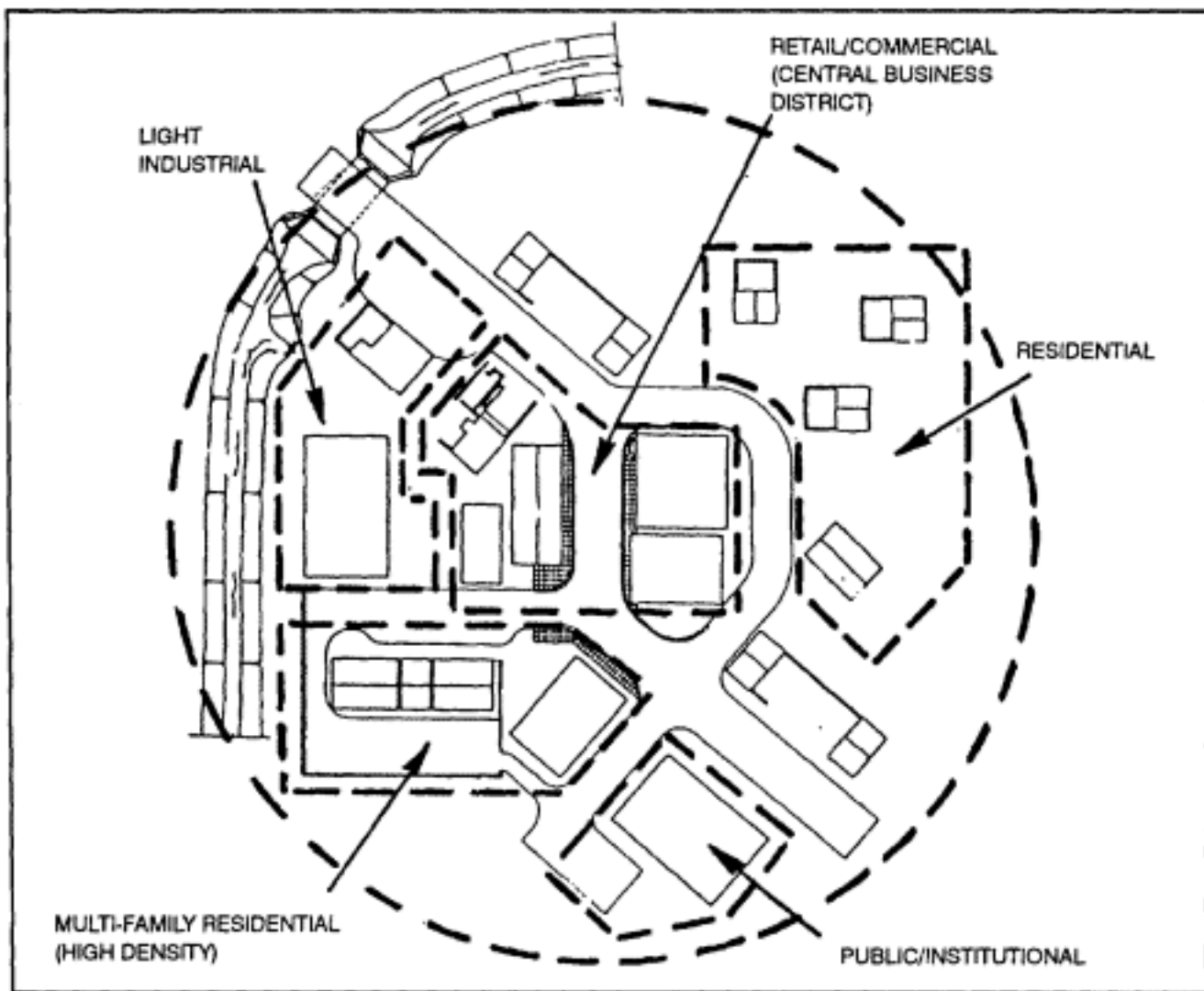

Figure 3-1. Typical 16-building CTF.



**Figure 3-2. Typical 32-building CTF.**

f. Buildings are arranged in a realistic urban pattern. Each CTF sector represents an area consisting mainly of residential, commercial, public institutional, high-density residential, or light industrial buildings. Buildings and streets are arrayed in a radial pattern with the greatest urbanization at the center (Figure 3-3).



**Figure 3-3. Urban layout with sectors.**

g. Other urban features pose a variety of terrain considerations. The street network includes one-lane and two-lane primary, secondary, local, and service roads. They join in T, L, and four-way intersections. The underground sewer system can be entered through manholes or through the basement of some buildings. Other features may be used to enhance realism such as signs, benches, newsstands, utility poles, street lights, vegetation, and rubble. Open areas next to the CTF can be used for peripheral maneuvering and staging areas. The specific details and layout of the CTF may vary from installation to installation.

h. Trainers often use the CTF to conduct a prepared defense. The large number of sandbags used may create excessive weight. Trainers must ensure the sandbags do not exceed the weight limits of the buildings. Otherwise, structural damage could occur, posing a safety hazard to soldiers.

### **3-2. TRAINING IN THE COLLECTIVE TRAINING FACILITY**

Training time and resources are limited, even under the best of circumstances. Since CTFs are so costly to build, they are a scarce training resource. This means units seldom have all the time they need in a CTF, so they must prepare and use what time they do have efficiently. To do so, the unit conducts preparatory training using the techniques and simulations outlined in this manual. A nearby air strip or helicopter LZ/PZ completes the scenario and provides a realistic threat of reinforcement.

### 3-3. TACTICAL EXERCISE WITHOUT TROOPS

A terrain walk and a TEWT may be conducted in a downtown area near the training facility to prepare leaders and to take advantage of the available time in the collective training facility. These techniques combine all previous individual and small-unit training into a final MOUT mission. Terrain walks and TEWTs are conducted to teach leaders to appreciate the tactical value of urban terrain.

a. The leaders should walk through areas containing all types of structures. They should use both city maps and standard military maps for orientation. Leaders learn the widths and patterns of streets and subterranean systems. They should see and appreciate the tactical significance of the following:

- Wood frame buildings, flammable, with weak walls and roof.
- Masonry buildings.
- Concrete, brick, or block family dwellings.
- Light concrete family dwellings.
- Steel frame office and commercial buildings.

b. Leaders should discuss the tactical significance of each of these areas while walking through them. This includes military factors of the terrain as they would be viewed by both an attacker and a defender.

c. A tactical situation is then introduced, and the terrain walk becomes a TEWT. Leaders are given a mission (attack, defend, retrograde) that is relative to the urban area. They are then required to analyze the situation, develop and war-game courses of action, brief their decisions back to their commanders, and issue implementing instructions.

d. The final step in the terrain walk/TEWT process is to repeat the downtown exercise within the MOUT CTF. This should be accomplished before the exercise. This step includes all soldiers, and it reinforces the lessons learned in the downtown terrain walk/TEWT. Practicing in this manner before the actual FTX, LFX, or STX allows leaders to reflect upon and refine what they have learned before they try it with their units.

e. Before conducting a TEWT in a real city, the unit should coordinate with city officials to avoid disrupting local government and business activities. This also may provide access to areas that would normally be closed to the public.

- (1) Coordinate with local police or security for access to the upper floors and roofs of tall buildings. This will provide vantage points for reconnaissance.
- (2) Assess the situation to determine the appropriate uniform for leaders to wear during the TEWT.
- (3) Coordinate for bus or vehicle parking.
- (4) Coordinate with the department of public works to gain access to or maps of the city's subterranean structure.
- (5) Coordinate for access to sturdily constructed buildings that may provide key MOUT

terrain. This can include jails, communications centers, government centers, parking garages, and so on.

(6) Coordinate with city emergency planning officials to discuss city SOPs, disaster plans, shelter locations, locations of hazardous materials, control of city electrical power, hospital, fire fighting, and police support. Discuss also using railcars, buses, and other equipment to create obstacles.

### **3-4. MOUT COLLECTIVE TRAINING EXERCISES**

Leaders use training exercises to train, evaluate, and practice performance-oriented collective tasks. Four types of exercises are discussed and outlined in this manual: the TEWT, STX, FTX, and LFX. Each is designed to help the trainer develop MOUT training skills and increase the unit's MOUT proficiency. The MOUT collective training exercises were developed using the standard CTF described in this chapter. The exercises may be modified to fit available MOUT facilities. This manual contains the following examples of STX and FTX scenarios and OPORDs (Appendix E):

- Infantry Rifle Platoon STX Attack.
- Mechanized Infantry Platoon STX Defend.
- Infantry Rifle Company FTX Attack.
- Mechanized Company or Team FTX Defend.

NOTE: These exercises were developed based on the principles outlined in the ARTEP MTPs and on the guidance provided in FM 25-3 and [FM 25-4](#).

## CHAPTER 4

# SPECIAL MOUT CONSIDERATIONS AND LESSONS LEARNED

*MOUT training strategy begins with the leader's knowledge of the urban operational environment and current US Army doctrine, tasks, and standards (FMs and ARTEPs). This chapter lists many of the special considerations and lessons that apply to MOUT. Leaders must learn these to construct an effective MOUT training strategy.*

### Section I. SPECIAL MOUT CONSIDERATIONS

MOUT doctrine changes as a result of changes in Army organizations, changes in the perceptions of threat, and lessons learned during actual MOUT operations. It is the potential need for precision application of combat power that forces the commander to include special MOUT considerations in his estimate process. This is because urban combat occurs more often than ever before. MOUT is special because it places demands on soldiers and leaders to use tactical techniques and procedures unique to MOUT.

#### 4-1. THE THREAT

Leaders must know the enemy. Due to the turbulence of Third World political and socioeconomic structures as well as the collapse of the former Soviet Union and the Warsaw Pact, this enemy is likely to include the conventional forces of Third World nations. Conflicts may range from regional wars to combat operations against insurgent forces. Leaders must conduct a threat evaluation and integrate the IPB process in the restrictive area of urban combat.

- a. During urban counterinsurgent, counter guerrilla, and counterterrorist operations, threat evaluation is similar to that for low-intensity conflict. Population status and underground routes are of primary concern.
- b. Threat capabilities increase as armed forces modernize and acquire technology in the following categories:
  - Munitions and ballistics.
  - Systems with interchangeable warheads, some designed for MOUT combat.
  - Precision-guided munitions.
  - Robotics.
  - Day or night target-acquisitions systems.
  - Elevated gun systems.
  - Obstacles.
  - Soft-launch hand-held antitank or flame weapons.
  - Nonlethal but incapacitating or lethal chemical and biological agents.

- Improved body armor.
- Improved communications.

## 4-2. PRECISION MOUT OPERATIONS

Precision MOUT is required when the enemy is mixed with noncombatants and strict limitations are imposed on collateral damage. These factors often increase the restrictiveness of the rules of engagement (ROE). The trainer's application of ROE and his initiative and innovation determine the type and quality of MOUT training his unit receives. A precision MOUT environment requires some special considerations:

- a. Civilian Personnel.** The presence of civilian personnel within the built-up area is a special challenge for the urban fighter. Naturally, the leader's main concern is the welfare of his soldiers; however, the safety and welfare of civilian personnel is the commander's legal responsibility. Soldiers must be trained to identify friend from foe (targets) and to use a different room-clearing procedure if civilians are inside.
- b. Identification of Friend from Foe.** Commanders must consider fratricide and injury to noncombatants when training for precision MOUT. Individual and collective training are the most important factors in avoiding fratricide. To help in identifying friend from foe, leaders must implement TTPs that ensure situational awareness, rehearsals, and high training standards. ([Appendix D](#) provides training tips on this subject.)
- c. Room-Clearing Procedure.** Soldiers use the following room-clearing procedure when they suspect civilian personnel may be in the room or in the battle area:
  - (1) All personnel must know the ROE before they can enter or clear a room or building.
  - (2) PSYOP/civil affairs teams can use a show of force to persuade civilians or enemy personnel to evacuate a building. Assigned or attached heavy weapons can provide the show of force by engaging an unoccupied corner of a building.
  - (3) Soldiers must try to use nonstandard entrances to buildings or rooms. These entrances may include holes in the walls caused by tank main gun fire or by direct-fire artillery.
  - (4) Soldiers engage enemy targets or process civilians as EPWs until their status is known.
  - (5) Soldiers take care at all times to avoid booby traps and mark them for following soldiers.
  - (6) Soldiers use concussion grenades when entering a room to avoid causing serious casualties.
  - (7) Soldiers use a standard means, such as paint, chalk, or engineer tape, to mark cleared rooms for those who follow.

## 4-3. COMBINED ARMS OPERATIONS

The dismounted infantryman bears the brunt of the battle in MOUT Armored vehicles—tanks, BFVs, artillery, engineer vehicles, and APCs—function largely in a decentralized direct support role. However, success depends on all elements working as a combined arms team to make the most of individual unit

abilities. Combined arms MOUT training is limited to the collective training facility (CTF) due to the destructive force and high cost of tank or BFV cannon ammunition. Nevertheless, the trainer leader must use every chance to train his unit in combined arms MOUT operations.

- a. Armored vehicles need infantry for security. Infantry elements clear ahead to protect vehicles from enemy antiarmor teams on ground level, upper floors, and rooftops. Infantry soldiers coordinate their movements with the vehicles and use prearranged signals to help vehicle gunners acquire targets.
- b. Armored vehicles, tanks, BFVs, and M113 APCs usually provide fire support from concealed positions during the initial attack of the built-up area. As the forward edges of the built-up area are cleared by dismounted elements, the vehicles can be moved forward—
  - (1) To neutralize enemy positions by fire. BFVs use their 25-mm cannons and 7.62-mm coaxial machine guns to engage targets on upper floors of tall buildings. Except when they are buttoned up, APCs can provide direct-fire support with their cupola-mounted .50-caliber machine guns or MK 19 40-mm grenade launchers.
  - (2) To destroy barricades and obstacles, the tanks, BFVs, M113 APCs, artillery, and CEVs fire their main guns or ram the appropriate obstacles.
  - (3) To set up roadblocks or an engagement area to kill any advancing enemy.
  - (4) To defend along with an infantry security element.
  - (5) To engage enemy armored vehicles, especially tanks.
  - (6) To secure part of the objective.
  - (7) To obscure the enemy's view with the smoke grenades and generator.
  - (8) To resupply ammunition and explosives.
  - (9) To evacuate casualties from the immediate area.
  - (10) To evacuate EPWs to designated collection points.
- c. Army aviation provides support for offensive and defensive operations in MOUT. Commanders must consider the enemy air situation, enemy air defense capabilities, terrain characteristics within and adjacent to the built-up areas, and the availability of Army and Air Force means of suppression.
  - (1) Army aviation support of combat operations within built-up areas includes aerial firepower, lifts for air assault, relocation of combat units, and observation.
  - (2) Missions in support of offensive operations include air assaults to secure key terrain and the employment of aerial weapons.
  - (3) Missions in support of defensive operations include rapid relocation of reserves or concentration of forces to meet unexpected enemy manpower. They also include employment of antiarmor aerial weapons at long ranges on approaches to the city or within the built-up area.

d. The CS and CSS elements must perform the same missions for combat on built-up terrain as they do on natural terrain. However, built-up areas impose special conditions that modify normal procedures, and support elements are attached to the lowest level possible.

(1) Army aviation performs several CS and CSS missions. These include resupply, observation, operation of sensory devices, rapid retransmission of messages, and movement or relocation of units. Helicopter movement is highly canalized, because power lines, smokestacks, towers, and tall buildings pose hazards to aircraft. Parks, sports arenas, streets, and even rooftops are potential landing zones for CS and CSS missions as well as for combat missions.

(2) Engineers have an increased role. Canalized movement makes obstacles more effective. Mobility operations eliminate obstacles and clear rubble. Engineers breach walls, destroy buildings, and clear fields of fire.

(3) Military police are critical to the control of the local populace and refugees. MP also guard key installations such as communication centers, government buildings, and utilities. The presence of many civilians increases the need for civil-military cooperation. The MP coordinate their operations with the local police when appropriate.

(4) Artillery fire, mortars, and CAS are closely controlled to avoid collateral damage. Artillery positions are also critical, because good firing positions are limited and fires are often masked by urban structures. Artillery must fire in the direct role more often during combat in a built-up area than in natural terrain.

(5) Ground surveillance radar is less effective in MOUT, because fields of observation are restricted. GSR is used mostly along large streets and beside open areas such as parks, lakes, and bridges. Its effectiveness in MOUT is greatest on the edge of the built-up area.

(6) Fields of fire for air defense weapons are narrower in a dense built-up area. The ADA positions that provide the best fields of fire are next to open areas, parking garages, on rooftops, and at the edge of the built-up areas. Soldiers must be careful to choose positions where urban structures cannot disrupt radar or interfere with target acquisition.

(7) The presence of unprotected civilians and the requirement to obtain authority for the use of any NBC weapons from the National Command Authority limit the commander's freedom to use chemical agents. Even though chemicals tend to linger inside buildings and underground systems, buildings do provide some protection from persistent chemical agents for the soldiers inside.

(8) Rubble can obstruct movement and disrupt the evacuation or recovery of broken equipment and casualties. Thus, the maintenance team and medical teams must make more on-the-spot repairs and provide more first aid in the forward area. Cannibalization of disabled equipment also increases.

#### **4-4. COMMAND, CONTROL, AND COMMUNICATIONS**

In MOUT operations, *planning is centralized and execution is decentralized.*

a. Soldiers and units require mission-type orders. Detailed control measures simplify the

decentralized execution of operations in MOUT. The increased difficulties inherent to commanding, controlling, and communicating from higher headquarters in MOUT demand increased responsibility and initiative from junior leaders.

b. Radio communications are less effective in MOUT than are field telephones and messengers. Pyrotechnic signals are hard to see because of buildings and smoke. Voice commands are degraded by the high noise level of battles within and around buildings. Because the dependability of communications available above company level is uncertain, units often fight without continuous communications from higher headquarters.

#### **4-5. FIREPOWER**

Targets are hard to acquire in MOUT, because dust, smoke, buildings, rubble, and shade each create cover and concealment. Also, targets are often exposed only briefly and at ranges under 100 meters. The restrictive nature of buildings, rubble, and road networks make vehicles vulnerable to short-range attacks.

a. The effects of certain weapons against walls vary. Units must know the capability of each weapon they employ. They can increase weapons effects by firing in combination or, for example, by firing so as to cause masonry to fall or fragment. ([FM 90-10-1](#), Chapter 8, provides more information about weapons effects.)

b. Range limitations in MOUT encourage close, violent combat between opposing forces. Therefore, soldiers rely greatly on automatic weapons, rocket launchers, hand grenades, and hand-emplaced high explosives.

c. Rifle rounds can penetrate most interior walls. Before soldiers fire, they must ensure that no friendly soldiers are on the other side of the wall. (See [FM 90-10-1](#), Chapter 8.)

d. Hand grenade blasts often penetrate interior walls. Soldiers must avoid endangering fellow soldiers when using hand grenades to clear a room. Concussion grenades are effective, but are less dangerous than fragmentary grenades. Using a grenade around a stairway poses a special risk: the grenade can roll down the stairs and injure friendly soldiers, including the soldier who threw the grenade. In confined areas, soldiers should always wear earplugs to protect themselves from the overpressure caused by exploding grenades.

e. Machine gun crews have difficulty firing grazing fire in MOUT. To do so, they must first clear rubble, walls, fences, and wreckage from their fields of fire. To cover dead spaces, they may instead have to fire plunging fires from an upper floor.

f. Leaders must plan for all available indirect fire support. Indirect fires are hard to adjust due to the limited observation offered by MOUT. Therefore, FOs must operate well forward in high structures. This high-angle firing reduces the maximum ranges of indirect-fire support weapons. However, the more streets the area contains, the more linear target patterns can be prepared for indirect-fire weapons systems. Mortars are well suited to firing in open areas and around lightly constructed buildings (though they have little effect on heavily constructed ones). Their high trajectory also makes mortars better suited than artillery for firing over tall buildings. Using mortars on hard surfaces requires the use of field-expedient measures for the baseplates and aiming stakes.

g. Artillery can provide effective direct fire.

h. Weapons with backblast require special positioning for use inside buildings (Table 4-1). These weapons should *never* be fired from inside any enclosure during training.

Weapon	Ceiling Height (feet)	Room Size (feet)	Ventilation to Rear (square feet)	Muzzle/Ground Clearance (Inches)
LAW	8	12 × 15	20	6
AT4	8	17 × 24	20	6
TOW	8	17 × 24	20	9

**Figure 4-1. Backblast requirements inside buildings.**

### DANGER

**FM 23-25 prohibits live firing the AT4 from inside any building. Doing so can kill you. The overpressure from the weapon's backblast severely damages the walls and roofs of most types of buildings. Even if you survive, the noise produced by firing an AT4 exceeds the highest possible reading (190 decibels) and will most likely burst your eardrums.**

**AR 385-62 prohibits live firing Dragon or TOW missiles from inside any building during training. Firing either of these weapons in a small area produces a backblast that will cause personal injury and damage both equipment and the building.**

(1) An open doorway 3 feet wide and 7 feet tall provides sufficient ventilation.

(2) M72-series LAWs require a clearance of at least 4 feet from the back wall of the room.

(3) Holes in walls, ceilings, or floors weaken the building's structural integrity but are still the most effective way to create ventilation. A safer, less effective way is to open doors or windows and to adjust the angle of fire.

Weapon	Minimum Arming Range (meters)
Dragon	65
TOW	65
LAW	10
AT4	10

**Table 4-2. Minimum arming ranges.**

(4) A weapon's minimum arming range determines how the weapon should be employed in urban terrain where short ranges are most useful (Table 4-2).

(5) TOWs are positioned on surrounding natural terrain to isolate the built-up area and to prevent enemy reinforcement. The TOW's maximum depression angle is 30 degrees. This can inhibit its usefulness, especially when placed high on a multistory building. However, if fields of fire and protection allow, the TOW can fire from within the built-up area, such as—

- (a) In the cover and concealment provided by buildings.
- (b) Dismounted inside of buildings, if enough space exists and the structure is strong enough.
- (c) Near parks, boulevards, highways, railway yards, lakes, or rivers, or along streets.

i. The MK 19 40-mm grenade machine gun fires 40-mm grenades at ranges of 1,500 meters (point targets) and 2,212 meters (area targets). The grenades produce casualties within 15 meters of impact. The HEDP round can penetrate 50 millimeters of armor. The MK 19 effectively covers dead spaces and large open areas. Employing this weapon in MOUT has some limitations: The minimum arming range is 18 to 36 meters; the minimum safe distance for firing is 200 meters in training and 75 meters in combat.

j. The BFV's 25-mm cannon affects urban targets differently. Its rounds can penetrate reinforced concrete 12 to 20 inches thick. They can also easily penetrate brick walls and bunker walls up to 36 inches thick.

k. The 120-mm tank round is also an asset to infantry soldiers fighting in MOUT—it can devastate masonry walls.

## 4-6. MANEUVER

Urban structures and rubble canalize and thus greatly impede movement of forces. Several factors cause

operations in built-up areas to differ from operations in other types of combat.

- a. Combat in built-up areas is time-consuming and tiring. It is characterized by a series of consecutive small battles for blocks, streets, buildings, and rooms. Units must both attack and defend along greatly reduced frontages.
- b. Planning is affected by the need to consider local civilians, refugees, and protected sites such as hospitals, churches, shrines, and works of art.
- c. Readily available covered and concealed routes include those inside and behind buildings and through underground passages. Both the attacker and defender can use these routes. Streets and alleys are a defender's kill zones; soldiers should avoid them or should move through them only with extreme caution.
- d. The existence and condition of roads, rail lines, and underground systems affect planning. Water bodies, such as canals, lakes, and rivers, also affect planning in that they reduce freedom of movement, especially for mechanized units. Reduced visibility aids in infiltrating and bypassing enemy positions.
- e. The attacker can obtain information about his zone of operation from street maps, sewer plans, and telephone directories. However, he must remember that these sources might be out of date. Other valuable sources of intelligence include aerial photographs, local civilians, refugees, prisoners, and defectors.
- f. The danger of cross fire increases when friendly units attack abreast. Remaining oriented is difficult, since units must try to avoid moving in streets.
- g. An attacking force is more likely to become fragmented in a built-up area than in other types of terrain. This reduces mutual support, resulting in numerous small-unit battles rather than one large, cohesive battle.
- h. Rubble, limited avenues of approach, and other obstacles decrease a large unit's chances of achieving surprise.
- i. The defender has the advantage of good cover and concealment, economy of force, strong fortifications, and knowledge of the terrain. The defender's good concealment complicates the attacker's task of locating and establishing the enemy's strength. The defender also has many opportunities for ambush and surprise.
- j. Fire poses a hazard to anyone occupying a building. Soldiers doing so should cover wooden floors with sand or dirt and stage buckets of sand and wet blankets to use in putting out fires.
- k. Acquiring targets using image-intensifying sights is more difficult in MOUT due to city lights and fires, which create background clutter.

#### **4-7. PROTECTION**

A built-up area usually offers good protection, the best of which is found in reinforced concrete or heavy-clad buildings, though subterranean structures can also be useful. Soldiers should avoid wooden buildings. Urban terrain may yield civilian supplies of military value, but these should be used only with

permission from higher headquarters.

a. **Conservation of the Force.** Security must be maintained in all directions. This includes to the flanks, front, rear, in buildings above, and in sewers below.

(1) To be defensible, a building must have floors strong enough to keep it from collapsing under the weight of debris and of the sandbags used to reinforce positions. It must have thick walls and floors so that the enemy cannot fire through them at the occupants. It should also be constructed of nonflammable materials and should have only a few windows.

(2) M113 APCs, BFVs, and tanks can establish fighting positions only in buildings with reinforced floors.

(3) Positions inside buildings must have overhead cover and provide protection from enemy soldiers already inside the building. Defending soldiers must be able to fight in any direction from their positions.

(4) Glass and flammable materials should be removed from occupied buildings, and electricity and gas turned off. Water, dirt, and blankets should be stockpiled for use in fighting fire.

(5) Fighting in a built-up area requires soldiers to use unique camouflage techniques. For example, burlap is a better helmet camouflage than foliage.

(6) Soldiers require hearing protection when they use a weapon with backblast. They must use goggles to protect their eyes from dust, splinters, glass shards, and other fragments.

b. **Actions to Sustain the Force.** Defenders from battalion level down should set up caches of ammunition, food, water, and medical supplies. Soldiers must take special measures to guard supplies from pilferage by civilians.

(1) Soldiers must be prepared for delays in resupply, since mobility is limited. They must fight with what they can carry. Underground systems support resupply both as supply routes and cache sites.

(2) Support can be interrupted often by enemy infiltrators or by small groups of bypassed resistance fighters. Units may fight for extended periods without support from the rear. For timely support, assets such as maintenance teams, mess teams, and so on must be located forward.

(3) Units need specialized equipment such as grappling hooks, crowbars, and rope ladders. Prepared defenses consume huge quantities of construction materials.

(4) Ammunition is the single greatest supply requirement due to the intensity of urban combat. Of these, grenades and small-arms ammunition are in greatest demand. In addition, the need for demolitions increases. However, fuel requirements are low; vehicles are used less in urban combat than in other types of combat.

(5) Decreased mobility hinders the evacuation of casualties, so more treatment must be available in place. The combat lifesavers and platoon aidmen bear this increased

responsibility. In-place treatment requires that first-aid items include field dressings and splints. Existing civilian hospitals, clinics, and nursing homes may be authorized for treatment of casualties.

(6) Vehicle maintenance requirements are less than in other types of combat. However, the rubble in this type of environment creates greater stress on the undercarriages of wheeled vehicles, and tires must be replaced more often.

## 4-8. LEADERSHIP

Good leadership and motivated soldiers are essential elements of combat power in MOUT.

a. **Leaders.** Fighting in built-up areas is fragmented; gains are often small. Therefore, units depend on the initiative, skill, and discipline of small-unit leaders and individual soldiers. Leaders must be competent and confident in their MOUT skills and must have the courage to accomplish their missions while isolated from their parent units. Soldiers and leaders require mission-type orders that are restrictive in nature but that allow for decentralized execution.

b. **Soldiers.** More soldiers are needed in MOUT, because MOUT produces more casualties.

(1) The proximity of civilians and unevacuated dead creates sanitation, hygiene, and disease-control problems. The disruption of normal services emphasizes the importance of field sanitation.

(2) The intensity of urban battle and the resulting combat stress increase the number of psychological casualties. For example, operating in sewers for the first time causes soldiers to experience extreme stress. If possible, they should undergo preliminary training before the actual operation.

(3) Soldiers fight closer to their enemy in MOUT, often at short ranges and sometimes face-to-face. They often fight for long periods with little rest. Since intense combat may produce only small gains in terrain, this can affect morale adversely; therefore, the importance of maintaining morale increases.

## 4-9. TERRAIN

The buildings above and underground passages below the streets add a vertical dimension to the urban battlefield. Enemy observation positions are likely in high, isolated structures such as steeples, or lone high-rise buildings.

a. Leaders must know the terrain wherever they fight. In MOUT, this means they must know the structural strengths and weaknesses of buildings and the locations of cellars, attics, underground systems (sewers, subways, and tunnels), power sources, utilities, and road networks.

b. The character of terrain in a built-up area varies greatly, even within a single town. For example, newer areas of a town tend to be open and lightly constructed. Older areas tend to be dense and heavily constructed.

## Section II. BATTLEFIELD OPERATING SYSTEM LESSONS LEARNED

Many lessons have been learned from military experiences between World War II and Operation Just Cause (Panama). These lessons apply to the areas of IPB, maneuver, fire support, mobility/countermobility/ survivability, CSS, command and control, and ROE. Within each area, lessons are listed by operation.

### 4-10. INTELLIGENCE PREPARATION OF THE BATTLEFIELD

The following lessons have been learned about IPB:

#### **Battle of Beirut**

*Human intelligence*—This may be effective inside a built-up area but be difficult to obtain outside.

#### **Operation Just Cause**

*Course of action*—To plan their COA, commanders must consider collateral damage, refugee control, and the reaction of the civilian population.

*Countermeasures*—To plan countermeasures, commanders must extend decision support templates and matrixes to highlight the long-term effects of combat operations.

*Focus of IPB*—CA teams, the chaplain, the S4, the S5, the MP, and others should contribute to the IPB process and expand its focus.

*Reevaluation*—The IPB process is dynamic and requires constant reevaluation. Refugee and unpredictable civil elements increase the need for periodic reevaluation.

*Organization*—CI/IPW teams should be placed OPCON to the maneuver elements.

*Contraband*—Soldiers involved in searches must know proper custodial procedures for contraband.

*Identification of key enemy personnel*—An in-depth, current biographical database that includes facial photographs must be maintained for all contingency missions.

*Patrols*—Neighborhoods must be patrolled to gather intelligence and establish presence among the people. This serves to both maintain their support and to protect them from the enemy and criminals.

*Local support*—As the local people gain confidence in US forces, they will volunteer more information. The commander and S2 must sort this information to determine what is useful.

### 4-11. MANEUVER—BY OPERATION

The following lessons have been learned about maneuver:

#### **World War II**

*Intervals*—Proper intervals must be maintained between soldiers to ensure coverage of all sectors of fire and to enable units to quickly react to contact.

*Reserve*—Commanders must carefully plan the missions of reserves, considering speed of maneuver, effectiveness, and logistical constraints.

## **Battle of Beirut**

*Weapons used for suppression*—Vulcans, tank guns, and artillery may be used in the direct-fire mode to effectively suppress the enemy.

*Tanks used for protection*—Tanks may be used for cover and to provide close suppressive fires for the infantry.

## **Operation Just Cause**

*Destruction and breaching exercises*—Soldiers are required to conduct destruction and breaching exercises as part of live-fire training. Where possible, soldiers should use scaled-down demolitions to prevent damage to private property.

*Night air assault operations*—These operations are effective and reduce friendly casualties.

*Building numbers*—Sketch maps individually numbering all buildings in the area are required for MOUT operations.

*Street lights*—Leaders must consider street lights in the urban environment as part of their METT-T analysis. These lights adversely affect NVDs and expose soldiers during movement between buildings.

## **4-12. MANEUVER—CLEARING BUILDING**

The following lessons have been learned about clearing buildings:

### **Operation Just Cause**

*Using concussion grenades*—To avoid fratricide and civilian deaths, soldiers should use concussion grenades, rather than fragmentation grenades, when operating in buildings with light interior walls.

*Clearing and securing*—Units should cordon off buildings before trying to clear or secure them. They should also block all entries and exits.

*Using aviation scouts*—Aviation scouts can help clear buildings. Then, once a cordon is in place, these scouts can observe enemy snipers, locate fleeing personnel, and vector ground units to intercept them.

*Using PSYOP*—Loudspeaker teams can encourage enemy personnel to surrender before soldiers enter a building.

*Disarming demolitions and booby traps*—EOD-trained personnel should be positioned to help disarm enemy demolitions or booby traps.

*Clearing buildings*—Units should clear buildings from the top down.

*Leapfrogging by floor*—Platoons should leapfrog by floor when clearing high-rise buildings. This keeps one platoon rested and available as a reserve for reaction missions.

*Limiting tracer use*—Units should limit their use of tracer rounds to avoid fires and collateral damage.

*Emphasizing restraint*—When conducting STXs for MOUT, leaders should emphasize that soldiers must exercise restraint in the use of force while clearing buildings or rooms.

*Clearing rooms and hallways*—Soldiers should use shotguns to clear rooms and hallways.

#### **4-13. MANEUVER—SNIPER EMPLOYMENT**

The following lessons have been learned about sniper use:

##### **Operation Just Cause**

*Suppression*—To avoid collateral damage when the civilian population is dense in the area of operations, snipers should be used to suppress enemy snipers and other enemy positions. Snipers can also call for and adjust indirect fire.

*Economy of force*—In MOUT, snipers can perform an effective economy-of-force role. They can secure key positions and screen flanks to free other soldiers to clear buildings and conduct patrols.

#### **4-14. FIRE SUPPORT**

The following lessons have been learned about fire support:

##### **Battle of Beirut**

*Mortars*—Mortars can be used to provide harassing and interdiction fires.

*Naval gunfire*—Naval gunfire effectively fixes the defender in his bunkers and, if he is operating outside, restricts his movement.

##### **Operation Just Cause**

*Danger-close*—Danger-close is the *normal* situation in MOUT.

*Target reference points*—Without clear reference points, TRPs do not work in limited visibility MOUT. Therefore, TRPs should be established in daylight or should be clearly marked.

*Registration alternative*—The position and azimuth determining system (PADS) can be used to ensure first-round accuracy when guns cannot be registered.

*Local security*—Fire-support units must provide their own local security when operating on a nonlinear front such as in MOUT.

*M203 grenade launchers*—This weapon can provide effective fire into windows.

*AC-130 aircraft*—The fire-support system on this aircraft provides pinpoint accuracy with its multiple weapons. The AC-130 is also available to provide accurate information on friendly and enemy movement and positions.

*Howitzers*—These can be used to effectively demonstrate firepower when fired in the direct-fire mode against buildings and at roadblocks.

#### **4-15. MOBILITY/COUNTERMOBILITY/SURVIVABILITY**

The following lessons have been learned about mobility/countermobility/survivability:

##### **Battle of Beirut**

*Using mines*—Defenders can use mines to block roads and canalize attackers.

*Breaching walls*—The most effective weapons for breaching walls are direct-fire artillery, tanks, and demolitions.

##### **Operation Just Cause**

*Antipersonnel rounds*—These should be fired at buildings to cover breaching teams.

*Roadblocks and checkpoints*—Units should place roadblocks and checkpoints in depth. However, to prevent the enemy from seeing a pattern, the roadblocks and checkpoints should be moved often.

*Balance of force protection and ROE*—Leaders should consider the balance between force protection and the ROE when positioning roadblocks.

*Roadblock turnover procedure*—Leaders should make roadblock turnover procedure as detailed as minefield turnover procedure or relief-in-place procedure.

*Firepower demonstration*—Both APCs and tanks can effectively demonstrate firepower at roadblocks.

*Cross-training*—Units must cross-train their engineers in explosive ordnance disposal (EOD) tasks, because EOD personnel may be unavailable to perform them.

#### **4-16. COMBAT SERVICE SUPPORT**

The following lessons have been learned about CSS:

##### **Operation Just Cause**

*Medical evacuation*—The limited availability of MEDEVAC assets requires that casualties be prioritized for evacuation and that MEDEVAC requests be complete and accurate.

*Civilian casualties*—Units should prepare to treat civilian casualties and plan for large numbers of nonemergency, humanitarian medical cases. Leaders should develop plans for medical evacuation of and collection points for civilians.

*Supplies*—Leaders should plan to have supplies prepackaged according to the specific needs

of their units.

*Captured enemy equipment and personnel*—Leaders should plan for LOGPAC vehicles to backhaul captured enemy equipment and prisoners. They should also plan storage for large quantities of captured weapons and equipment.

*Logistical reporting*—Leaders must ensure accurate logistical status reporting.

*Maintenance*—Preventive maintenance checks and services are especially important during contingency operations due to the limited support available.

*Casualties*—Leaders must ensure combat units have readily available body bags for friendly, enemy, and civilian casualties.

*Tires*—More tires are required for MOUT than for other types of operations due to excessive wear caused by driving through debris.

*Refugee support*—Leaders must plan enough CSS assets to provide food, clothing, shelter, and medical attention to refugees. They must also plan refugee evacuation routes away from combat operations. PSYOP assets can direct refugees to collection points.

*Consolidation*—Leaders must consolidate, account for, and reissue CTA 50-901 items as casualties occur.

*War trophies*—Rules must be published and rigidly enforced on personal and unit war trophies and souvenirs. All such items must be collected and recorded, along with their sources, at battalion level.

*Redeployment inspections*—Just before redeployment, the chain of command must conduct detailed inspections of all containers, vehicles, and personal equipment for contraband and "souvenirs."

## **4-17. COMMAND AND CONTROL—BY OPERATION**

The following lessons have been learned about command and control:

### **World War II**

*Communications*—Within a built-up city, communications may depend mainly on radio.

### **Battle of Beirut**

*Nets*—Decision-making by small-unit commanders can reduce the strain on tactical communication nets.

*Telephone lines*—These can be ineffective in an urban environment, because messages can be easily intercepted by tapping.

### **Iran/Iraq War**

*Decision-making*—Urban combat moves decision-making and other responsibilities down to NCO level.

## Operation Just Cause

*Standardization*—Standard terms and graphics should be used.

*Reporting*—Units should practice SOPs for reporting to ensure they work.

*Transmission time*—To streamline reporting procedures and thereby reduce transmission time, leaders should incorporate training in the use of operation schedules (OPSKEDs) and execution checklists.

*Visual signals*—Leaders should use visual signals to supplement radio and should use whistles to lift and shift fires.

*Assignment of grid coordinates*—Leaders should practice converting locations on city maps to grid coordinates for calls for fire, aerial resupply, and exact locations.

## 4-18. COMMAND AND CONTROL—LIAISON OFFICERS

The following lessons have been learned about use of liaison officers:

### Operation Just Cause

*Employment*—Leaders must exchange LOs, which is critical to a successful operation.

*Staffing*—Leaders must plan for sufficient liaison officers to operate around the clock during continuous operations.

*Training*—Leaders must integrate LO exchanges into training exercises and at combat training centers (CTCs).

*Military police*—An MP unit attached to an infantry brigade for stability operations should provide an LO to the brigade.

## 4-19. RULES OF ENGAGEMENT

The following lessons have been learned about ROE:

### Operation Just Cause

*Intent*—Leaders must explain the intent of the ROE in terms soldiers can understand, using examples to illustrate their points. They should then develop STXs to rehearse the ROE. Soldiers must understand and visualize the meaning of the ROE.

*Changes*—Leaders must consider how changes to the ROE will affect force protection. They must communicate changes quickly and effectively down to the lowest levels. Leaders should develop a system of checks to ensure soldiers receive and understand the intent of the latest changes.

*Noncombatant training*—Leaders should include noncombatants in training exercises and at CTCs to allow soldiers to practice observing ROE procedures and controlling refugees.

*Roadblocks*—Leaders should practice establishing roadblocks in a tactical context, where contact with noncombatants or the enemy is likely.



## APPENDIX A

# MOUT CLASSROOM SUBJECTS

*The following list includes topics recommended for MOUT classroom instruction. The primary references for these topics are [FM 90-10](#) and [FM 90-10-1](#). The instructor should also refer to other manuals that pertain to the indicated subject matter. When other manuals do not specifically address subjects within the context of MOUT, the instructor should apply the MOUT considerations discussed in FM 90-10 or FM 90-10-1 to his topic of instruction. The local training support center can supply a list of available graphic training aids as well as other types of training aids. Training aids may have to be prepared locally. If so, sufficient time must be allowed for this. FM 90-10-1 also provides information about field-expedient equipment.*

SUBJECT AND APPROPRIATE REFERENCES	INDIV	SQUAD	PLT	CO	BN
Threat doctrine (FMs <a href="#">100-2-1</a> thru <a href="#">100-2-3</a> )	X	X	X	X	X
US Army doctrine (FMs <a href="#">7-7J</a> , <a href="#">7-8</a> , <a href="#">7-10</a> , <a href="#">7-20</a> , <a href="#">71-1</a> , <a href="#">71-2</a> , <a href="#">90-10</a> , <a href="#">90-10-1</a> , and <a href="#">100-20</a> )	X	X	X	X	X
Building classification (FMs <a href="#">90-10</a> and <a href="#">90-10-1</a> )	X	X	X	X	X
Legal aspects of MOUT and ROE ( <a href="#">FM 27-10</a> )	X	X	X	X	X
Employment of antitank weapons (FMs <a href="#">7-91</a> and <a href="#">90-10-1</a> )	X	X	X	X	X
Urban terrain analysis (FMs <a href="#">5-33</a> , <a href="#">90-10</a> , and <a href="#">90-10-1</a> )		X	X	X	X
Weapons effects on urban structures (FMs <a href="#">90-10</a> and <a href="#">90-10-1</a> )	X	X	X	X	X
Casualty evacuation (FMs <a href="#">7-8</a> , <a href="#">7-10</a> , <a href="#">7-20</a> , <a href="#">21-11</a> , and <a href="#">21-75</a> )	X	X	X	X	X
Logistical operations					

(FMs <a href="#">7-7J</a> , <a href="#">7-8</a> , <a href="#">7-10</a> , <a href="#">7-20</a> , <a href="#">71-1</a> , <a href="#">71-2</a> , 100-8, and <a href="#">100-10</a> )		X	X	X	X
Historical analysis of actual urban battles (see References in rear of this manual)		*	*	*	*
Nuclear, biological, and chemical operations (FMs <a href="#">3-3</a> , <a href="#">3-4</a> , <a href="#">3-5</a> , <a href="#">3-6</a> , <a href="#">3-11</a> , <a href="#">90-10</a> , and <a href="#">90-10-1</a> )	X	X	X	X	
Subterranean operations, planning, and navigation (FM s <a href="#">7-98</a> and <a href="#">90-10-1</a> )	X	X	X	X	X
MOUT attack task organization (FMs <a href="#">7-10</a> , <a href="#">7-20</a> , <a href="#">71-1</a> , <a href="#">71-2</a> , <a href="#">101-5</a> , <a href="#">90-10</a> and <a href="#">90-10-1</a> )				X	X
Priorities of work in the defense of a built-up area (FMs <a href="#">7-7J</a> , <a href="#">7-8</a> , <a href="#">7-10</a> , <a href="#">7-20</a> , <a href="#">71-1</a> , <a href="#">71-2</a> , and <a href="#">90-10-1</a> )	X	X	X	X	X
Cordon and search (FMs <a href="#">7-10</a> , <a href="#">7-20</a> , and <a href="#">7-98</a> )				X	X
Urban field hygiene ( <a href="#">FM 21-10</a> )	X	X	X	X	
Smoke operations (FMs <a href="#">3-6</a> , <a href="#">3-50</a> , and <a href="#">3-100</a> )		X	X	X	X
Army aviation (FMs 1-111, <a href="#">1-112</a> , and <a href="#">100-26</a> )				X	X
Operations, communications, or signal security (FMs <a href="#">11-50</a> , <a href="#">21-60</a> , <a href="#">24-1</a> , <a href="#">90-10-1</a> , and <a href="#">TC</a> <a href="#">24-20</a> )		X	X	X	X
Intelligence and target acquisition in a built-up area (FMs <a href="#">34-1</a> , <a href="#">90-10</a> and <a href="#">90-10-1</a> )			X	X	X
Employment of night vision devices (FM <a href="#">90-10-1</a> and <a href="#">STP 7-11BCHM14-SM-TG</a> )	X	X	X	X	X
Rear operations (FMs <a href="#">7-20</a> and 90-14)				X	X

## GSR Employment

(FMs [34-1](#) and [90-10-1](#))

X

X

## Urban navigation

(FMs 21-26 and [90-10-1](#))

X

X

X

X

X

## Handling of EPWs and refugees

(FMs [19-40](#) and [41-10](#))

X

X

X

X

X

## Sniper employment

(ARTEP 7-92-MTP and TC 23-14)

X

X

X

X

## Fighting with armor attached

(FMs [7-7J](#), [7-8](#), [7-10](#), [71-1](#), [71-2](#), [90-10](#),  
and [90-10-1](#))

X

X

X

\*Leader task only

## APPENDIX B

# AUDIOVISUAL MATERIALS

*Several films and television tapes are available on various MOUT topics. The local TSC provides these and other materials to supplement MOUT instruction.*

How to Fight—Military Operations on Urbanized Terrain,  
Part 1, Offense.

Catalog Number: TF 7-6230.

Length: 30 minutes.

Format: Film or videotape.

Scope: Mechanized infantry task force in the deliberate attack.

Level: Commander through individual soldier.

Remarks: This emphasizes the isolation phase of deliberate attack and of individual and team techniques.

How to Fight—Military Operations on Urbanized Terrain,  
Preparing a Village for Defense.

Catalog Number: TF 7-6231.

Length: 24 minutes.

Format: Film or videotape.

Scope: Mechanized infantry company in the prepared defense of a village.

Level: Company commander through individual soldier.

Remarks: This focuses mainly on company and platoon defensive planning. It addresses Threat task organization and tactics as well as interaction with civilians.

Commandant's Call—An Loc.

Catalog Number: None. Produced by the US Army Infantry School.

Length: 29 minutes 30 seconds.

Format: Videotape.

Scope: North Vietnamese attack on An Loc during the 1968 Tet offensive in South Vietnam.

Level: Commander.

Remarks: Black and white. This is a videotaped lecture and discussion emphasizing the roles of tanks and antitank helicopters in MOUT.

### Battle Line—Stalingrad.

Catalog Number: TF 40-101.

Length: 26 minutes.

Format: Film.

Scope: Battle of Stalingrad during World War II from the initial German offensive through the German capitulation.

Level: Commander through individual soldier.

Remarks: Black and white. This film includes good combat footage of low-level city fighting.

### Introduction to Military Operations on Urbanized Terrain.

Catalog Number: 2E/010-071-1722-B.

Length: 6 minutes.

Format: Videotape.

Scope: Presents real-world scenario and MOUT training footage.

Level: Individual soldier.

Remarks: This introductory videotape can be used to gain soldiers' interest. It contains no MOUT instruction.

### Combat Assault of a Built-Up Area.

Catalog Number: 2E/071-0740-B.

Length: 9 minutes 42 seconds.

Format: Videotape.

Scope: Platoon attack of a building.

Level: Platoon leader through individual soldier.

Remarks: Black and white. This videotape includes a platoon assault plan and entry and clearing techniques.

### House to House Fighting.

Catalog Number: 2E/010-071-1155-B.

Length: 26 minutes 33 seconds.

Format: Videotape.

Scope: Individual skills and small-unit tasks in combat in the cities.

Level: Platoon leader through individual soldier.

Remarks: Black and white. This is a British World War II training videotape. It presents individual skills and small-unit collective tasks well and still applies today.

#### Military Government in an Enemy City—Part 1, Initial Entry.

Catalog Number: TF 41-2589.

Length: 16 minutes.

Format: Film or videotape.

Scope: G5/military police actions on initial occupation of an enemy city.

Level: Commander through platoon leader.

Remarks: Black and white. This presents the objectives and operations of G5/military police. It includes the laws of occupation, plans for government, plans for the functions and operations of special teams, a survey of damage, and a survey of people's needs.

#### Military Government in an Enemy City, Part 2, Public Safety.

Catalog Number: TF 41-2590.

Length: 17 minutes.

Format: Film or videotape.

Scope: This covers emergency disaster plans, support of civilian fire department, control of penal institutions, civilian registration, and collection of weapons and explosives.

Level: Commander through platoon leader.

Remarks: Black and white. This addresses measures that can be used by military safety personnel to prevent civilians in an occupied enemy city from interfering with military operations.

#### Military Government in an Enemy City—Part 3, Public Health.

Catalog Number: TF 41-2591.

Length: 16 minutes.

Format: Film or videotape.

Scope: Covers operations by military public health personnel in an occupied enemy city.

Level: Commander through platoon leader.

Remarks: Black and white. This addresses measures the military should take to safeguard friendly soldiers and civilians.

## Military Government in an Enemy City—Part 4, Civilian Evacuation.

Catalog Number: TF 41-2592.

Length: 25 minutes.

Format: Film or videotape.

Scope: Covers mass civilian evacuation operations.

Level: Commander through platoon leader.

Remarks: This presents methods used by military staffs to evacuate in 72 hours the 40,000 civilians who occupy an enemy city.

Remarks: This film is good for training offensive operations. However, the videotape extract from this film is less useful.

### b. Tanks and Infantry in Urban Combat.

Nationality: Israeli.

Language: English translation.

Length: 8 minutes.

Format: Videotape.

Scope: Tank/mechanized infantry attack of a village.

Level: Small-unit leader.

Remarks: Black and white. This videotape presents an overview of MOUT. It includes diagrams and footage of tanks and infantry MOUT training.

### c. Fighting in Industrial Areas.

Nationality: German.

Language: English translation.

Length: 25 minutes.

Format: Film.

Scope: Defense of a rail yard, including sewer system considerations, civil-military cooperation, and combat support.

Level: Small-unit leader through individual soldier.

Remarks: This film was produced by the German Infantry School in Hammelburg. It discusses the necessity of immobilizing an industrial area without destroying it. The film presents the chemical

and high-voltage electrical dangers inherent to this type of operation, and it emphasizes the need for expert civilian assistance.

d. Defense of House/Village.

Nationality: German.

Language: English translation.

Length: 30 minutes.

Format: Film.

Scope: West German doctrine concerning the defense of a village.

Level: Small-unit leader through individual soldier.

Remarks: Black and white. This film was produced by the German Infantry School in Hammelburg. It includes preparation of fields of fire, reinforcement of terrain, and deception plans.

e. Offensive Operations in a Village.

Nationality: German.

Language: German.

Length: 30 minutes.

Format: Film.

Scope: Company-level doctrine for attacking a village.

Level: Small-unit leader through individual soldier.

Remarks: Black and white. This film was produced by the German Infantry School in Hammelburg. It includes individual techniques for clearing a house, weapons and equipment requirements, unit organization, and support materiel.

f. Weapons Effects in and Around Built-Up Areas.

Nationality: German.

Language: German.

Length: 30 minutes.

Format: Film.

Scope: The effects of various weapons at different ranges and on different targets; controllable and uncontrollable effects of weapons on walls and buildings.

Level: Small-unit leader.

Remarks: Black and white. This film was produced by the German Infantry School in

Hammelburg.

g. Military Operations in Populated Areas.

Nationality: Russian.

Language: English translation.

Length: 30 minutes.

Format: Film.

Scope: Soviet combined arms doctrine in the offense.

Level: Commander through small-unit leader.

Remarks: Black and white. This film, produced about 1943, provides lessons that still apply.

h. Road to Ortona.

Nationality: Canadian.

Language: English.

Length: 30 minutes.

Format: Film.

Scope: World War II footage of MOUT in Italy.

Level: Commander through small-unit leader.

Remarks: Black and white. This film concerns fighting with engineer support in and around rubble and urban debris. The last six minutes of the film is a discussion of the material presented.

i. The Mechanized Attack in an Urban Area.

Nationality: French.

Language: English translation.

Length: 20 minutes and 35 seconds.

Format: Videotape.

Scope: Mechanized battalion combined arms offensive operations.

Level: Commander.

Remarks: This videotape addresses urban combat considerations. It shows techniques small-units can use around and on top of buildings.

## APPENDIX C

# MOUT TRAINING COMPLEXES

*Table C-1 shows the locations and the number of both types of MOUT training complexes (MTCs): US Army MOUT assault courses (MACs) and collective training facilities (CTFs).*

LOCATION	NUMBER OF MACs	NUMBER OF CTFs	NUMBER OF BLDGs IN CTF
Fort Benning, GA	1		
Fort Hood, TX	1	1 1	16 32
Fort McClellan, AL		1	16
Fort Ord, CA	1	1	32
Fort Pickett, VA	1	1	16
Hohenfels, Germany (Combat Maneuver Training Center)		1	32
Schofield Barracks, HI	1	1	16

**Table C-1. Collective training facilities.**

## APPENDIX D

# TRAINING TIPS

*The effectiveness of MOUT training programs depends on the imagination and thoroughness applied to a training plan. All trainers—from training managers to junior leaders—must prepare their units to fulfill their MOUT mission. They can employ procedures that are based on training doctrine and on proven techniques. This appendix discusses several techniques for planning MOUT training. Trainers choose which to use based on training needs and on available resources.*

### D-1. AFTER-ACTION REVIEW

Important lessons can be learned from a properly conducted AAR. The AAR provides immediate feedback for training events. It is a structured review process that allows training participants to discover for themselves what happened, why it happened, and how it can be improved. The AAR is a professional discussion that requires the active participation of those being trained.

- a. An AAR is not a critique, it is better than a critique ([FM 25-100](#)).
  - (1) The AAR focuses directly on key METL-derived training objectives.
  - (2) The AAR emphasizes meeting Army standards; it does not determine success or failure.
  - (3) Leading questions are asked during the AAR to encourage participants to discover by themselves the lessons they have learned from the training event.
- b. During the AAR, the evaluator leads participants and helps them—
  - (1) Establish what happened. They restate training objectives and determine what actually happened during the training event.
  - (2) Determine what aspects of the training event could be improved.
  - (3) Determine what should be done differently.
  - (4) Perform the task again. Repeating appropriate tasks immediately after they are discussed reinforces lessons learned. The evaluator leads the group in determining exactly how participants will perform differently the next time the task is performed.
- c. In conducting an AAR, the training evaluator or AAR leader—
  - (1) Ensures all soldiers participate.
  - (2) Determines the causes of mistakes and corrects training deficiencies.
  - (3) Keeps the topic of the discussion at a level suitable for those present.
  - (4) Turns every major point into a lesson learned.

- (5) Avoids embarrassing participants.
- (6) Discusses leaders' problems and deficiencies in private rather than in front of their soldiers.
- (7) Always tries to end the AAR on a positive note.

## D-2. AUDIOVISUAL MATERIALS

These materials include films and videotapes. Although they can supplement training, they must not replace it. Appendix B provides a list of many good films and videotapes that address MOUT. Trainers should review them to ensure they pertain to the training objectives and should avoid using the parts that do not. They should rehearse with the actual audiovisual equipment (projector or video cassette player, television, extension cord, and so on) at the training site. Historical films on real MOUT battles can stimulate soldiers' interest and illustrate instructions. These aids may be available from learning centers or from the installation's training support center (TSC).

## D-3. CONCURRENT TRAINING

Concurrent training allows groups of soldiers to train on different tasks at the same time. This requires a plan for rotating soldiers between the stations that teach different tasks. This is referred to as round-robin training. Concurrent training is an efficient training technique, because it makes good use of training time and facilities. Trainers should use the example training exercises provided in Appendix E to develop scenarios to meet their units' needs.

- a. **MOUT Training Complex.** Concurrent training in the MTC works best with performance-oriented tasks. It also requires detailed planning, control, and coordination, and more assistant trainers. Concurrent training is well-suited for small-unit competition with dedicated instructors. Every unit is scored on the tasks performed at each station. At the end of training, the trainers tally scores and recognize the best unit.
- b. **MOUT Assault Course.** The MAC is well-suited to concurrent training. After mastering the tasks at one station, a group of soldiers rotates to the next station in the sequence. To avoid bottlenecks at any of the stations, trainers should plan instruction in blocks that last about the same length of time. Concurrent training is often conducted with dedicated instructors at each station. The advantage of this technique is that it ensures uniformity of performance standards and saves on trainer preparation time. The disadvantage is that soldiers are not always trained by their leader. Therefore, when feasible, small-unit leaders should rotate with their soldiers from station to station so they can take part in the training. This demands much preparation and expertise from leaders.
- c. **Concurrent Exercises.** Concurrent exercises are a variant of concurrent training. In a concurrent exercise, elements of the same unit receive different missions. These missions correspond to each element's training objective for that exercise. This technique can be used during FTXs, STXs, or CFXs. For example, one unit attacks, a second supports by fire, and a third acts as a reserve. Also, elements of the same unit can challenge each other. For example, if a trainer has been training his unit in MOUT offense and defense, he can create a scenario in which one force is required to attack the other. This allows the unit to train with an OPFOR without an extra

investment of resources. Leaders must remember to carefully plan the force ratios between the OPFOR and counterattacking forces.

#### D-4. DEMONSTRATIONS

Trainers can demonstrate the correct way to perform the tasks. A demonstration can include a skit, film, or videotape. With skill, trainers can combine these types of demonstrations. A live demonstration is often the most effective teaching method, because it holds soldiers' interest. However, the trainers must demonstrate the task slowly so the soldiers can see all the steps. They must emphasize key points and stop the action to explain each one. Some of the MAC stations have open sides or are covered only with target cloth. Range personnel might allow trainers to remove this cloth temporarily so the soldiers can see what is happening inside. The trainers can then use video cameras to film the action inside the buildings. Soldiers can watch the demonstrations on a remote monitor, and trainers can use the videotapes again.

#### D-5. EVALUATORS

Soldiers from the training unit or from another unit can evaluate MTC training, especially during the *run* stage of training in an STX, FTX, or CFX. Commanders attach evaluators to units while the units perform their tasks. A dedicated evaluator provides objective and thorough comments on the unit's performance throughout all stages of the exercise. Evaluators monitor the critical point of the action, but must avoid interfering—they must not disrupt unit performance or undermine realism. They must be trained and given standardized evaluation guides if their feedback is to be meaningful; MTPs and T&EOs are a good start. Evaluators conduct AARs alone or along with the unit leader. When conducting them jointly, the evaluator and leader take time to clarify their points. Evaluators can also score unit competitions.

#### D-6. EXERCISES

Exercises help train soldiers and leaders to work well together and to use their equipment and resources properly.

a. **Battle Simulation Exercise.** A BSX is a military war game that recreates combat situations on a map or terrain model. Pieces or markers represent units, and rules govern movement, fire, losses, and other aspects of actual combat. A BSX is the best type of exercise for leader training. Each leader leads the same type of unit he will lead in combat. A heavy/light scenario requires him to conduct MOUT as he would in real combat. Other players control the OPFOR.

(1) Players need not learn the game rules in detail; doing so could distract them from the MOUT tactics and techniques being taught. Instead, trainers and controllers are the game experts. This allows the players to concentrate on the training objectives.

(2) The training support center may be able to provide battle simulation war games. Blockbuster is a battle simulation adapted for MOUT from the war game, Dunn-Kempf. The American-Canadian-Australian-British Urban Game (ACABUG) is a detailed simulation that might also help in training for MOUT. Other military war games can be adapted to MOUT, and some commercial games are based on MOUT subjects.

b. **Command Field Exercise.** The CFX is used mainly to train commanders, staff, and junior

leaders. It employs all of a unit's command and control assets, with a number of subordinate elements reduced according to a set scale. For example, one soldier might represent an entire squad, one vehicle a platoon, or one base gun an entire battery,

(1) Preliminary training, such as CPXs, TEWTs, MAPEXs, and BSXs, should precede the CFX. Each scenario shows a background situation. Units conduct operations, and controllers resolve battle outcomes. The exercise ends with an AAR. Fewer controllers are needed in a CFX than in an FTX. However, if the number of unit functions increases, the number of controllers must increase also.

(2) Combat in built-up areas entails centralized planning with decentralized execution.

(a) *Centralized planning* can be practiced in a CFX, but it can be practiced more economically in a CPX, TEWT, MAPEX, or BSX.

(b) *Decentralized execution* means that the battle in a built-up area is led by platoon, squad, and team leaders. However, because these elements are scaled down in a CFX, trainers usually find STXs, FTXs, and T&EOs to be more useful.

c. **Command Post Exercise.** A CPX allows leaders and staff to perform their tasks in a unit CP, where they receive information in the form of reports that require certain reactions. A scenario shows them the initial tactical situation; subsequent events recreate a developing combat situation.

(1) CPXs are most effective in achieving the following general training objectives:

- Preparing plans.
- Issuing orders.
- Building teams.
- Reconnoitering, selecting, and tactically occupying CP locations.
- Establishing and using communications.
- Preparing and sending reports.
- Coordinating between subordinate elements.

(2) A company CP is usually associated with a battalion level or higher CPX, or the company can conduct its own CPX. The headquarters section can setup a CP in a CTF building, then can displace to another building. The CP must be fully operational by a certain time. The unit repeats the CPX until they meet the required standards. The section can practice hiding wire on pavement, stringing it between buildings, and running it through sewers. The CP can practice receiving reports, logging them on DA Forms 1594, posting situation maps, and sending reports forward to higher headquarters.

d. **Field Training Exercise.** An FTX allows units to execute collective tasks under conditions that closely resemble actual MOUT. FTXs are suitable for the CTF.

(1) An FTX requires much time, resources, and planning. The time is well spent if units master their collective tasks. An FTX is an excellent way to conduct the *run* stage of collective training. OPFOR and MILES make the most of the training value of the FTX.

(2) A unit's MOUT FTX training plan addresses ROE, restrictions, and the controller plan.

Soldiers must know the exercise's training objectives before they begin so they can focus on the correct tasks. Every participant, regardless of position or rank, must fully understand all safety requirements.

(3) To get the most from time in the field, leaders must plan in great detail. The concept of multiechelon training demands that they consider what training can occur at each level in each event.

**e. Live-Fire Exercise.** The MAC accommodates live-fire training at several of its stations. [Chapter 2](#) and local range regulations provide specific guidance for conducting LFXs in the MAC. Live-fire training allows soldiers and leaders to maneuver while firing service ammunition. An LFX is most productive when preceded by non-live-fire practice (dry fire or dry run). The training in an LFX occurs in the following sequence, which can be shortened if time and ammunition dictate. However, dry fire should *always* precede live fire. An AAR should follow each repetition, and units should not proceed to the next level of difficulty until they master the current step:

(1) Dry fire to practice unit drills and individual tasks.

(2) Conduct an AAR.

(3) Practice drills and tasks a second time, with limited expenditure of ammunition, to show the complex coordination of fire and maneuver required.

(4) Conduct an AAR.

(5) Practice the exercise a third time with full use of ammunition to create realism and to build confidence.

(6) Conduct an AAR.

(7) Practice the exercise a fourth time, preferably with ammunition, at night or during limited visibility.

(8) Conduct an AAR.

(9) Practice the exercise a fifth time, using ammunition saved by crews or units, to sustain proficiency and to provide initial training for soldiers or units who have never had live-fire training.

**f. Map Exercise.** A MAPEX lets participants plan and execute MOUT operations using maps, overlays, sand tables, photographs, or models. MAPEXs develop teamwork and skills in terrain analysis, planning, coordination, order writing, and employment of MOUT tactics.

(1) Use a model of the CTF, which is an excellent training aid for instructing soldiers and leaders. Gather leaders around the map or model and have them devise a tactical plan. Use figures or markers to represent friendly units and the OPFOR. Create tactical situations that challenge participants to react as they would in real combat.

(2) Incorporate direct fire, casualties, NBC, logistics, and civilians into the problem. Ensure the ROE for each exercise are clear to participants,

(3) Have plenty of detailed maps available for use in the MAPEX and in the planning and execution of subsequent CFX operations.

**g. Situational Training Exercise.** STXs are mission-oriented, limited exercises used to train a unit to perform a single collective task or a series of related tasks and drills. With their distinct start and stop points, STXs represent a segment of battle. (Appendix E provides examples of platoon STXs.) An STX is more flexible and complex than a single T&EO or drill. In fact, an STX typically includes drills, leader tasks, and separate individual tasks, and involves a unit's "slice" of external combat, CS, and CSS assets. An STX often precedes an FTX or CFX, and can be conducted in the CTF by creating a brief situation and mission. For example, MP company commanders might want to teach their soldiers about straggler control. They can string the tasks together into small scenarios such as the one shown in Table D-1, describe tactical situations that produce stragglers from nearby units, and use other soldiers to represent the stragglers. Then they can train soldiers to process these stragglers at straggler collection and transport points.

**h. Tactical Exercise Without Troops.** A TEWT focuses on leader and staff tasks. The senior trainer selects the terrain for the MOUT TEWT. Either the CTF or a real village, town, or city is appropriate. The procedure for conducting a TEWT is as follows:

- (1) Create a scenario and enemy situation, and assign missions.
- (2) Allow the leaders to devise their reconnaissance plans and implement their plans on the terrain.
- (3) Require them to brief subordinate leaders while walking the terrain.
- (4) Ensure their plans include the following tasks:
  - Analyze the terrain.
  - Employ units according to the terrain analysis.
  - Emplace weapons.
  - Devise a unit plan.
  - Employ combat, CS, and CSS assets.
- (5) Conduct an AAR.

EVENT	TASK	SITUATION
1	Each leader (SFC and above) plans a straggler control operation for a division-sized area.	Provide an oral or written OPORD and a map of the area. Give a realistic suspense date to complete the plans.
2	Each platoon conducts straggler control operations.	Provide a tactical situation with a lot of stragglers in the area. Include a written or oral OPORD to establish straggler control in the AO. Provide a straggler estimate.
3	Each soldier uses correct techniques for detecting and identifying stragglers.	Provide soldiers with a current list of stragglers, a list of units operating in the area, a straggler SOP, and a situation where MP are manning a straggler control post or a tactical control post.
4	Each squad establishes a straggler collection point.	Provide a small building, communications equipment, a field desk, a unit straggler control SOP, and a specified location for a straggler collection point. Have stragglers arrive at the collection point.
5	Each soldier assigned to a straggler collection point correctly processes stragglers.	Provide a straggler control plan or SOP, daily straggler lists, necessary blank report forms (military police reports), and stragglers.
6	Each patrol takes into custody combat-fatigued, hysterical, frightened, or dazed stragglers.	Have stragglers mimic these characteristics as they are processed.

## D-7. MULTIPLE INTEGRATED LASER ENGAGEMENT SYSTEM

MILES realistically recreates the effects of actual fire in training. It uses laser adapters on the weapons and laser-sensitive equipment on the soldiers and vehicles. A MILES weapon emits a laser beam when fired. Accurate fire strikes the laser-sensitive equipment and scores a hit. MILES requires soldiers to aim accurately and to use cover and concealment effectively. When used with an OPFOR, MILES offers realistic training. It is an excellent training aid for an FTX or STX. It is also effective in the MAC as a substitute for live fire. The two major shortcomings of MILES are that it allows soldiers to seek cover behind structures that normally would not protect them, and that it does not replicate suppression.

## D-8. NAVIGATION

Navigational techniques for built-up areas differ from those needed on other terrain.

- a. A typical 1:50,000-scale military map provides insufficient detail for accurate navigation. Therefore, soldiers must learn to navigate using commercial maps, sketches, and aerial photographs. Leaders must learn how to plan operations using these same items.
- b. Underground navigation is a special challenge. Soldiers must know subway plans and be able to identify tunnels, elevated tracks, stairways, and other critical features. They must learn how to measure distance, remain oriented, and mark their routes.
- c. Destruction often erases built-up features that could aid in navigation. Soldiers must learn how to orient using distinctive, difficult-to-erase features such as bridges, waterways, towers, and intersections.
- d. Leaders conduct navigational exercises in an actual built-up area. Soldiers must move from point to point while controllers at each point monitor and verify soldiers' progress.
- e. The global positioning system (GPS) is a navigational aid that triangulates with satellites to calculate position. However, this system may be affected by nearby tall buildings, and its effectiveness decreases more inside buildings or underground.

## D-9. LIMITED VISIBILITY TRAINING

MOUT involves day and night operations. FTXs, STXs, CFXs, and CPXs are the most profitable exercises for night training, especially with an OPFOR. ([FM 90-10-1](#), Appendix I provides more information about limited visibility operations in MOUT.)

- a. Field-expedient lighting, NVDs, illumination, and electrical lighting must be exploited when the tactical situation allows. Soldiers must learn discipline in their use of light. They must also learn the lighting techniques that allow them to carry out their MOUT training program.
- b. Situational awareness is the soldier's knowledge of his location, the locations of friendly forces, and the locations of the enemy on the battlefield. Situational awareness is the key to avoiding fratricide, especially during limited visibility operations. Units must plan to use all the equipment and devices available to mark friendly units and to avoid fratricide, without exposing themselves to enemy observation.
- c. Reverse-cycle training should be part of a MOUT training program. However, combat requires continuous operations—not fighting at night and sleeping during the day. Limited visibility fighting skills are perishable, but they can be sustained and improved by effective training. The goal is for every soldier to operate as effectively at night as during the day.

## D-10. OPPOSING FORCES

Trainers should include OPFOR in some of their training, especially during FTXs, CFXs, and STXs. OPFOR counter tasks should be developed to ensure the trainers can train the collective tasks. Leaders develop a thorough control plan for scenarios that include an OPFOR. This plan should include uniform and vehicle markings, rules for ammunition, safety instructions, controller guidance, and guidelines for

handling prisoners. ROE must clearly specify the limits of close combat between soldiers.

- a. Using an OPFOR heightens soldiers' interest by giving them a "real" opponent. This fosters unit competition and realism, especially when the OPFOR is used in addition to MILES.
- b. An OPFOR challenges leaders' ability to improvise. However, this free-play scenario should be monitored to ensure the unit meets training objectives.
- c. The OPFOR can use threat MOUT doctrine. OPFOR uniforms, mock documents, overlays, and equipment add realism and intelligence to the scenario. Leaders conduct preliminary training for the OPFOR, which helps the OPFOR recreate the threat's MOUT tactics.
- d. Civilians should be integrated into training scenarios. Dummies or targets can represent civilians, and soldiers can dress in civilian clothing to represent refugees, local inhabitants, or enemy agents.

## **D-11. IDENTIFICATION OF FRIEND FROM FOE (TARGETS)**

MOUT assault courses can be used to train soldiers to identify targets. To improve soldiers' skills, trainers can switch some of the regular targets with friendly targets. Live-fire targets can vary from enemy targets painted with a simple red star to targets dressed in civilian clothing. MILES equipment is less effective at short ranges than at long ranges. However, it can be used for target identification in the MAC or in the CTF. MILES targets must have MILES sensors. These targets can be objects, or they can be soldiers dressed as previously described.

## **D-12. OPPORTUNITY TRAINING**

Leaders must take advantage of their limited, valuable training time. "Hip-pocket" (opportunity) training allows leaders to capitalize on unexpected training opportunities. However, this requires leaders to always be prepared with instructional lessons for their soldiers. Lessons relevant to MOUT that require little preparation are readily available. Soldier's manuals, MTPs, or this manual can quickly provide effective MOUT training.

## **D-13. PHYSICAL TRAINING**

Combat in built-up areas places extraordinary physical demands on soldiers. Upper body strength is greatly taxed. Therefore, physical training with emphasis on upper body development is an important part of any MOUT program.

- a. Consider establishing a MOUT obstacle course in the MTC. This can include such hard skills as climbing ropes, throwing grappling hooks, running on stairs, entering windows, and crawling through sewers.
- b. Hold a unit competition to see which team can finish the course the fastest. This may take the form of a relay race if the course is short. For longer courses, run each team as a group and include obstacles that require team MOUT skills such as the two-soldier hand lift.
- c. Combine this course with urban navigation. Create an urban orienteering course to challenge soldiers' technical, physical, and navigational skills. Provide each soldier or team with maps that specify routes and skills to be performed at each point.

## D-14. TELEVISION TRAINERS

Television trainers (TVTs) are portable videotape systems that provide instant training records. They are effective except in darkness, dusk, or dampness.

- a. Play the tape immediately after recording an exercise. For example, show it on a television monitor during the AAR. Soldiers readily relate to what they can see, especially when they see themselves.
- b. Erase or save the tape. Record a single unit's progress on successive exercises. Soldiers can then easily see repeated mistakes or their own improvement.
- c. When using the TVT, keep these points in mind:
  - (1) Practice using the TVT camera beforehand. Know how sensitive it is to light and sound.
  - (2) Fully charge the battery before use. The TVT's battery life is short, so be prepared to recharge it.
  - (3) Hide the camera operator during the exercise so that the filming does not distract the soldiers.

## D-15. TRAINING BY THE NUMBERS

Training by the numbers is an effective technique to introduce new tasks and skills to soldiers. It is most appropriate during the *walk* phase of training; it is also best for individual tasks and drills since they are performed the same way every time.

- a. First, thoroughly analyze the task by dividing it into parts. Place these parts in their proper sequence. For example, if you are teaching soldiers how to enter a building using a grappling hook, one of the performance measures for the soldier's manual task is "Enter a Building." Divide this performance measure into the following sequence:
  - Step 1.** Stand as close to the building as possible.
  - Step 2.** Grasp a few coils of rope and the grappling hook in the throwing hand; grasp the remainder of the rope in the nonthrowing hand.
  - Step 3.** Throw the hook and coiled rope upward in a gentle, even, upward lob from the throwing hand.
  - Step 4.** With the nonthrowing hand, release the rope and allow it to play out.
  - Step 5.** Once the grappling hook is inside the target area (or on the roof), pull the rope until the grappling hook is solidly hooked before beginning the climb.
  - Step 6.** Avoid crossing windows of uncleared rooms.
  - Step 7.** Maintain the lowest possible profile while entering the window: go in either leg first or head first.
- b. Explain the entire sequence to soldiers and demonstrate it, if appropriate. Have soldiers go

slowly through each step in order and give them feedback on their performance at each step. Repeat the steps until each is done properly, then perform all steps in order at slow speed. When soldiers are proficient, have them perform all steps in order at normal speed.

## **D-16. VARIED SCENARIOS**

Leaders must avoid using stereotyped scenarios in the CTF. Using predictable avenues of approach into the facility produces stereotyped tactical solutions.

- a. Vary the direction of attack, the types of enemy vehicles and weapons, and the kinds of units. Give units different missions and different slices of combat, CS, and CSS assets.
- b. Use the facility to represent a city or a village occupied by a unit. The surrounding natural terrain then assumes importance to the tactical situation.
- c. Begin the exercise with OPFOR in the CTF. Allow the OPFOR to deploy a few buildings away. This resembles a city combat situation where all fighting occurs within the urban terrain.

# APPENDIX E

## EXAMPLE STXs AND FTXs

*This appendix provides examples of offensive and defensive scenarios for combat in built-up areas. Section I includes two platoon situational training exercises (STXs), and Section II includes two company field training exercises (FTXs). STXs are based on single missions, and FTXs are based on multiple missions. Each platoon STX can be developed into a live-fire exercise. The example exercises are designed to help the commander develop, sustain, and evaluate the unit's mission proficiency.*

### Section I. PLATOON STXs

This section provides two example STXs, an attack STX for an infantry rifle platoon and a defend STX for a mechanized infantry rifle platoon.

#### INFANTRY RIFLE PLATOON SITUATIONAL TRAINING EXERCISE

##### ATTACK

#### 1. Objective.

This example STX trains collective, leader, and individual tasks for the platoon operation, Attack in a Built-Up Area.

#### 2. Interface.

This STX is supported by two drills from [ARTEP 7-8-Drill](#): React to Contact, and Enter and Clear a Building.

#### 3. Training.

a. Guidance. [ARTEP 7-8-MTP](#) (Chapter 4), [FM 25-100](#), and [FM 25-101](#) provide training guidance, tips, and enhancers for planning and executing STXs. The trainer should review the individual, leader, and collective tasks to be performed during the STX to determine which require initial or refresher training.

b. General situation.

(1) The exercise scenario is as follows: Contact with the enemy has been reestablished. Initial reports indicate he is at 65 to 70 percent strength and has not been reinforced. His defensive positions are located in the town of McKenna and are not well established. He has the capability for indirect fire and CAS; he has already used chemicals and will probably do so again. The platoon receives an order to prevent the enemy from establishing a heavily fortified defense in McKenna. Such a defense could prevent friendly forces from continuing

offensive operations.

(2) This exercise begins when the platoon leader receives the company FRAGO, and it ends after the platoon consolidates and reorganizes on the objective. An AAR should be held after completing the task, React to Contact, and at the completion of the exercise. If necessary, portions of the exercise should be repeated until the platoon performs them well. Figure E-1 provides a graphic scenario of task performance for the STX Attack. Table E-1 provides a recommended sequence of T&EOs from [ARTEP 7-8-MTP](#) and the time allotted for each portion of the STX.

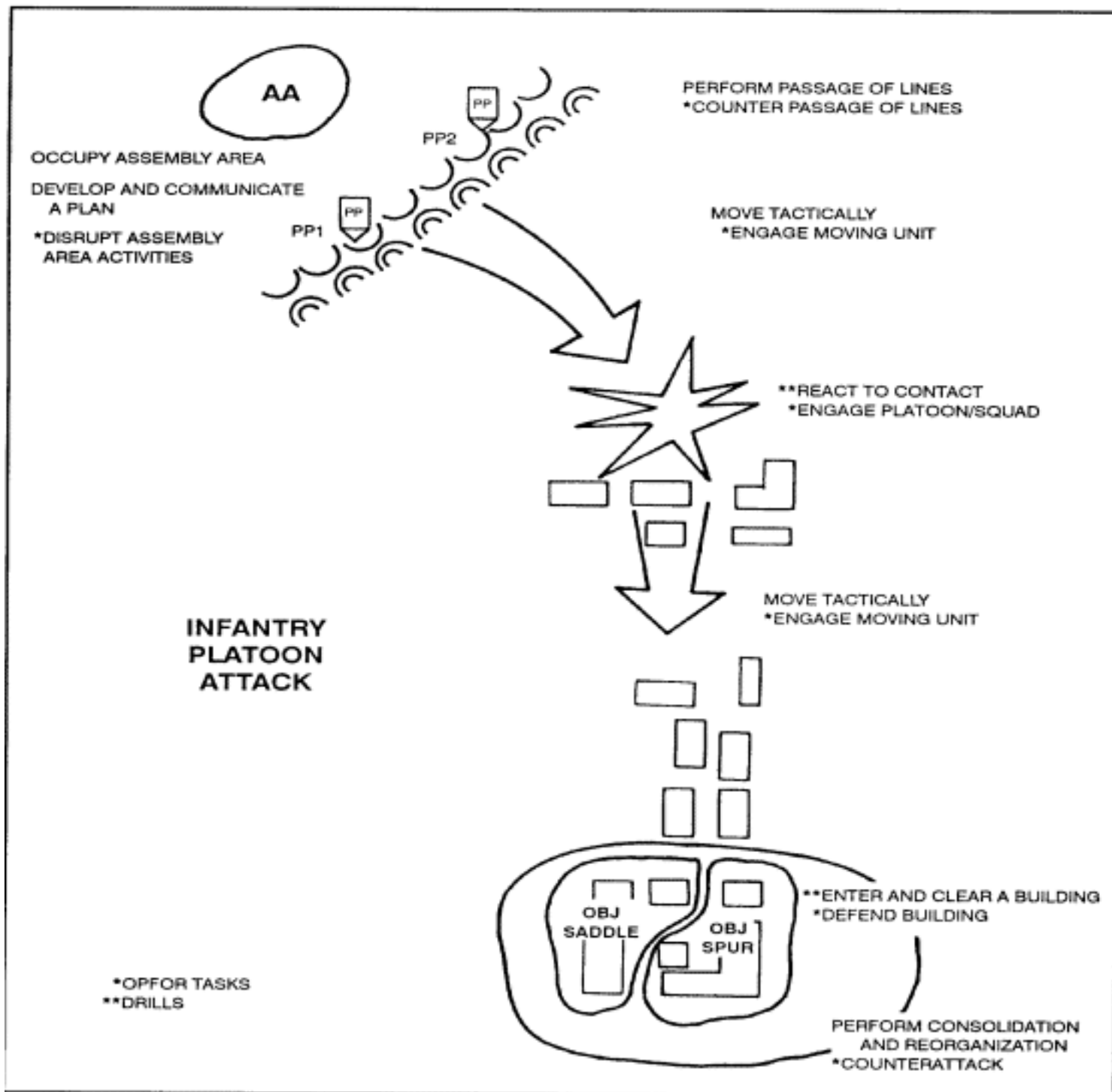

**Figure E-1. Graphic scenario of task performance for STX Attack.**

EVENT	ACTION	ESTIMATED TIME
1	Occupy Assembly Area	1 hr
2	Develop and Communicate a Plan	1 hr
3	Perform Passage of Lines	1 hr
4	Move Tactically	1 hr
5	React to Contact (drill)	30 min
6	Conduct Intermediate AAR	30 min
7	Move Tactically	30 min
8	Enter and Clear a Building (drill)	1 hr
9	Perform Consolidation and Reorganization	1 hr
10	Conduct Final AAR	1 hr
	* Total Time	8 hr 30 min
* Conducting an exercise at night or in increased MOPP requires additional time.		

**Table E-1. Sequence of events and times for STX Attack.**

c. Special situation. The platoon is part of a company in a secure assembly area when a FRAGO at attack is received (Figure E-2).

1. SITUATION. The company is opposed by one platoon.

a. Enemy Forces. The enemy is at 65 to 70 percent strength. He is preparing a defense in McKenna (*MOUT site*) to prevent friendly forces from continuing to attack along the McKenna avenue of approach. He is expected to use artillery-delivered nonpersistent nerve agents in the defense of McKenna.

b. Friendly Forces. (*Battalion designation*) attacks (*date-time group*) to destroy enemy forces at OBJ COWBOY (*McKenna*) in order to pass follow-on forces, allowing friendly forces to continue the attack.

2. MISSION. (\_\_\_) Company seizes OBJ HORSE (*McKenna*) vicinity (*grid*) NLT (*date-time group*) to prevent the enemy from establishing a heavily fortified defense.

3. EXECUTION.

a. Concept of the Operation. See ANNEX A (operations overlay). The company will move in a wedge to Assault Position 1, then they will assault McKenna to seize OBJ HORSE,

consolidate, and reorganize.

(1) Maneuver. (*Evaluated*) Platoon will lead the company and be the main effort in the attack. They will seize OBJ SADDLE, vicinity (grid), to allow passage of friendly elements through McKenna. (\_\_\_) Platoon will move on the company's left and seize OBJ SPUR, vicinity (*grid*), to protect the left flank of the main effort. (\_\_\_) Platoon will move on the company's right and establish a support-by-fire position located vicinity (*grid*).

(2) Fire Support. Fires will be used to obscure movement to OBJ HORSE and to suppress the enemy during the assault. Priority of indirect fires is to (*evaluated*) Platoon, which is allocated one priority target (120-mm mortar).

b. Tasks to Maneuver Unit.

(1) (*Evaluated*) Platoon.

(a) Use Passage Point 1.

(b) Orient defense from TRP 2 to TRP 3.

(c) Be prepared to employ a wire-mined obstacle vicinity TRP 5 during consolidation.

(2) (\_\_\_) Platoon.

(a) Use Passage Point 2.

(b) Orient defense from TRP I to TRP 2.

(3) (\_\_\_) Platoon

(a) Use Passage Point 2.

(b) Orient defense from TRP 3 to TRP 4.

c. Coordinating Instructions.

(1) Company RP is located (*grid*).

(2) Company linkup *is* (*grid*).

(3) MOPP1 is in effect (*date-time group*).

(4) Selective rubbleing is authorized. Destruction of an area larger than one city block requires brigade commander approval.

**Figure E-2. Example FRAGO for STX Attack (continued).**

**4. Support Requirements.**

a. Minimum trainers/evaluators: The company commander or platoon leader serves as the trainer or primary evaluator for this exercise. At least one more controller or evaluator is required with the

OPFOR. Other platoons being trained or evaluated should make the breach and provide support. These platoons will also need trainers or evaluators.

b. Vehicles/communications: All vehicles organic to the platoon should be included. The OPFOR should also possess some combat or combat support vehicles.

c. Opposing force: The OPFOR should consist of at least a reinforced squad.

d. Maneuver area: A training area at least 4 by 15 kilometers is needed for cross-country movement and infiltration. A collective training facility (CTF) is the ideal objective area. The terrain should offer multiple covered and concealed approaches to the objective.

e. Consolidated support requirements: This exercise requires the items shown in Table E-2.

<u>AMMUNITION</u>	<u>DODAC</u>	<u>BASIC LOAD</u>	
5.56-mm	1305A080	80 rounds per rifle	
5.56-mm	1305A075	200 rounds per M249 LMG	
ATWESS cartridge	1370L367	4 (Viper, for LAW) 3 per Dragon	
Hand grenade body, M69	1330G811	2 per rifleman	
Hand grenade fuze (practice)	1330G878	2 per rifleman	
Simulator, projectile, ground burst, M115A2	1370L594	20 per exercise	
Simulator, hand grenade, M116-series	1370L601	20 per exercise	
Simulator, booby trap		5 per exercise	
Simulator, HC		5 per exercise	
Practice demolitions			
Practice fuzes			
<b>OTHER ITEMS</b>			
Batteries			
BA 200 (6-volt)		12 each	
BA 3090 (12-volt)		140 each	
<u>MILES EQUIPMENT</u>	<u>PLATOON</u>	<u>EVALUATORS</u>	<u>OPFOR</u>
M16-series rifle	32	2	15
M249 LMG system	6	0	2

Controller gun	0	2	0
Small-arms alignment fixture	0	1	0

**Table E-2. Consolidated support requirements for STX Attack.**

## 5. Evaluation.

Table E-3 lists the T&EOs from [ARTEP 7-8-MTP](#) used to evaluate this STX,

TASK/FUNCTION	TASK NUMBER
PERFORM PASSAGE OF LINES	7-3/4-1125
MOVE TACTICALLY	7-3/4-1134
OCCUPY ASSEMBLY AREA	7-3/4-1136
DEVELOP AND COMMUNICATE A PLAN	7-3/4-1605
PERFORM CONSOLIDATION AND REORGANIZATION	7-3/4-1607

**Table E-3. T&EOs used to evaluate STX Attack.**

### **MECHANIZED INFANTRY PLATOON SITUATIONAL TRAINING EXERCISE**

#### **DEFEND**

#### 1. Objective.

This example STX trains collective, leader, and individual tasks for the platoon operation, Defend MOUT/Building.

#### 2. Interface.

This STX is supported by two drills from [ARTEP 7-8-Drill](#): React to Contact and Enter and Clear a

## Building.

### 3. Training.

a. Guidance. [ARTEP 7-8 MTP](#) (Chapter 4), [FM 25-100](#), and [FM 25-101](#) provide training guidance, tips, and enhancers for planning and executing STXs. The trainer should review the individual, leader, and collective tasks to be performed during the STX to determine which require initial or refresher training.

b. General situation.

(1) The exercise scenario is as follows: Latest INTSUMs indicate that enemy forces are expected to use a high-speed avenue of approach to counterattack. The approach is dominated by a small built-up area containing strongly constructed buildings. The enemy has the capability for indirect fire, CAS, and chemicals. A defense in and around the town is necessary to deny the enemy the use of the avenue of approach. The platoon, as part of a larger force, is ordered to occupy and prepare defensive positions that overlook the avenue of approach. Indirect fire is available.

(2) Conduct of the exercise. This exercise begins when the platoon receives an OPORD to move to establish a platoon defensive position. An AAR should be conducted after soldiers enter a building and clear a room, and a final AAR should be conducted once all evaluation notes are compiled. If necessary, portions of the exercise should be repeated until the platoon's performance is satisfactory.

(3) When the platoon receives a warning order to prepare to move to establish a defense, the platoon is part of a company, which is part of a task force, and is located in an assembly area. Figure E-3 provides a graphic scenario of task performance for the STX Defend. Table E-4 provides a recommended sequence of T&EOs from [ARTEP 7-8-MTP](#) and the time allotted for each portion of the STX.

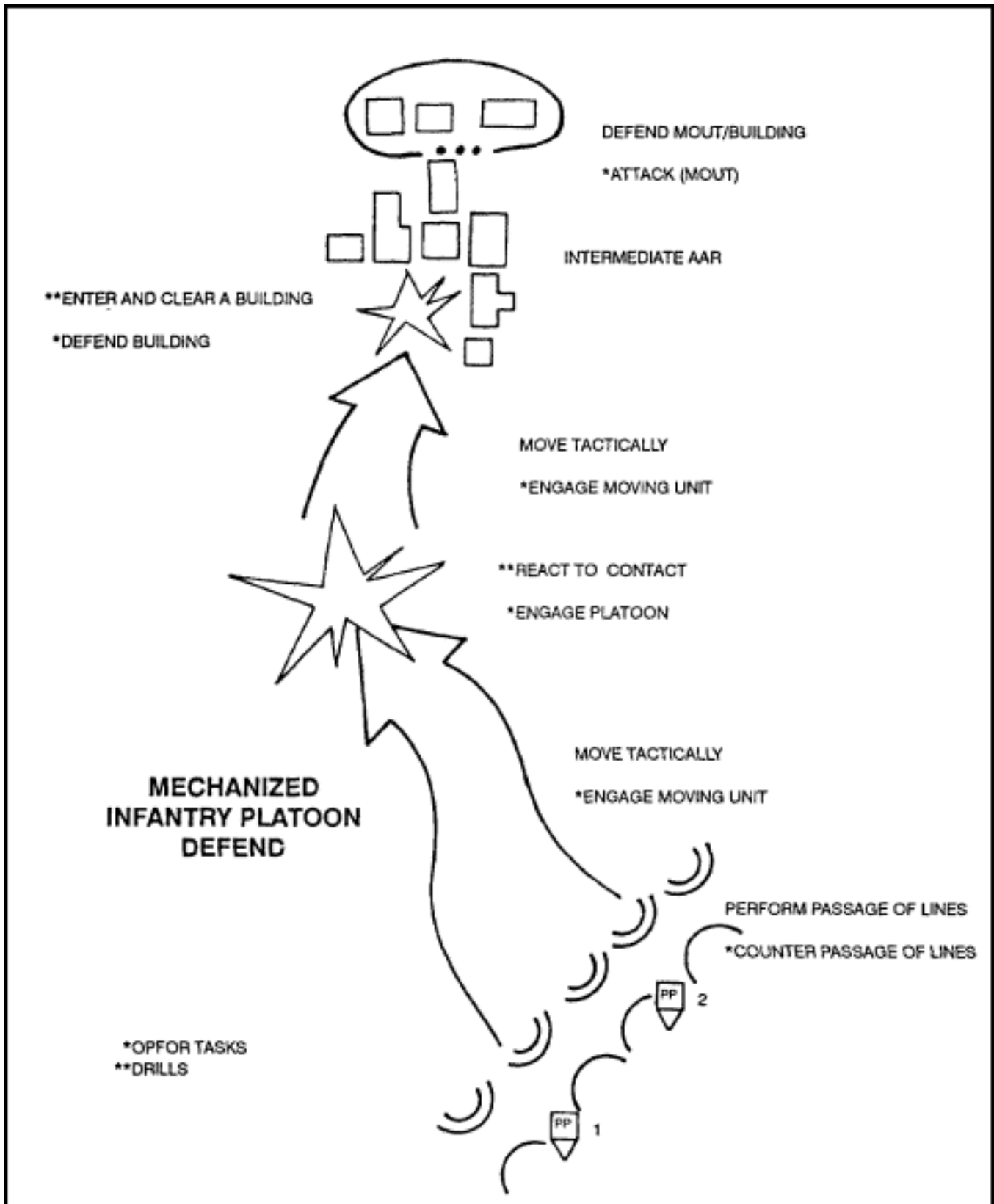

**Figure E-3. Graphic scenario of task performance for STX defend.**

EVENT	ACTION	ESTIMATED TIME
1	Perform Passage of Lines	1 hr
2	Move Tactically	30 min
3	React to Contact (drill)	1 hr
4	Move Tactically	30 min
5	Enter and Clear a Building (drill)	1 hr
6	Intermediate AAR	30 min
7	Defend MOUT/Building	6 hr
8	Conduct Final AAR	1 hr
	<b>* Total Time</b>	<b>11 hr 30 min</b>
* Conducting an exercise at night or in increased MOPP requires additional time.		

**Table E-4. Sequence of events and times for STX defend.**

c. Special situation. Thirty minutes after receiving the warning order, the platoon receives the company OPORD (Figure E-4).

**Figure E-4. Example OPORD for STX Defend.**

\_\_\_\_\_  
(Classification)

Copy no. \_\_\_\_ of \_\_\_\_ copies  
 \_\_\_\_ Battalion, \_\_\_\_ Infantry  
 Unit location or place of issue  
 Date-time group (with time zone)  
 Message reference number

OPERATION ORDER NO. \_\_\_\_

References: Map, series no. sheet no. \_\_\_\_, edition \_\_\_\_

Time Zone Used Throughout the Order: \_\_\_\_

TASK ORGANIZATION:

\_\_\_\_ Platoon \_\_\_\_ Platoon(-) \_\_\_\_ Platoon

Company Control  
 Company HQ  
 1/1/C-52d Engr  
 1/2 (Reserve)  
 Company Trains

## 1. SITUATION.

### a. Enemy Forces.

(1) Composition, Disposition, and Strength. We are opposed by elements of the 7th MRD of the 24th CAA. Contact has been broken and the enemy has withdrawn north of the grid line. Several platoon-sized outposts are located in the battalion sector vicinity (*grid*), (*grid*), and (*grid*). The platoons are organized into three 10-soldier squads, each equipped with a BTR-70 and an assortment of Soviet small arms, including AK-74s, RPKs, and RPGs. Latest INTSUMs indicate the enemy outposts are at 60 to 70 percent strength.

(2) Capabilities. The enemy units are well entrenched in their defensive positions. The strongpoints have dedicated fire support assets and are expected to use nonpersistent nerve agents to prevent coordinated attacks. Although air parity exists, the enemy can establish air superiority for brief periods.

(3) Probable Course of Action. Intelligence indicates the enemy strongpoints will continue to fortify their positions until relief arrives within 24 hours, in the form of a main enemy counterattack.

b. Friendly Forces. (\_\_\_) TF defends in sector NLT (*date-time group*) along PL (\_\_\_) to deny enemy forces use of avenue of approach (\_\_\_). (\_\_\_) TF must be prepared to continue movement forward of PL (\_\_\_), on order.

(1) Missions of units on left and right are (*as required*).

(2) (\_\_\_) TF defends in sector NLT (*date-time group*) from (*grid*) to (*grid*) to (*grid*) to contain any penetrations of the brigade sector.

(3) (\_\_\_) Battery, (\_\_\_) Battalion provides DS to 1st Brigade.

c. Attachments and Detachments. 1/1/C-52d Engineers attached.

2. MISSION. (\_\_\_) Company blocks enemy forces NLT (*date-time group*) to prevent them from using high speed avenues of approach through (*MOUT site*), and to prevent the enemy from counterattacking into the battalion sector.

## 3. EXECUTION.

a. Concept of the Operation. See ANNEX A (operations overlay). We will prevent the enemy from using the high speed avenues of approach through (*MOUT site*) by moving to the site and establishing a blocking position, which will overwatch platoon BPs covering the main avenues. We will block in depth by placing two platoons forward and one back and by maintaining a reserve to block any penetration. We must ensure our sectors of fire are placed to mass fire at the decisive point.

(1) Maneuver. (*Evaluated*) Platoon will act as the main effort, blocking from BP (\_\_\_), vicinity (*grid*), to prevent enemy penetration of PL (\_\_\_). (\_\_\_) Platoon will occupy BP (\_\_\_), vicinity (*grid*), to block enemy movement into the main effort's left flank. (\_\_\_)

Platoon will occupy BP (\_\_\_) to prevent the enemy from making a coordinated attack on the main effort.

(2) Fire Support. Purpose of fires is to disrupt the enemy when his counterattack reaches PL (\_\_\_). Priority of indirect fires is to (*evaluated*) Platoon, which is allocated two 155-mm priority targets, one of which may be used as an FPF.

(3) Intelligence. Priority of collection is to identify and locate enemy combat reconnaissance patrols and the enemy main effort.

(4) Engineering. During movement to the battle position, obstacles are used to ensure mobility. During blocking actions, the purpose of obstacles is to prevent the enemy from advancing on larger streets and to canalize him into more restrictive terrain. Priority of effort is to countermobility. Priority of support is to (*evaluated*) Platoon.

b. Tasks to Maneuver Units:

(1) (*Evaluated*) Platoon:

(a) Conduct passage of lines using PP 1.

(b) Lead the company movement after crossing the LD. Be prepared to react to enemy contact when MOUT site is reached.

(c) Enter and clear building(s) (*number determined by commander*).

(d) Occupy BP (\_\_\_) and orient on TRPs 2 and 3.

(e) Establish an OP vicinity (*grid*) to observe main avenue of approach.

(2) (\_\_\_) Platoon:

(a) Conduct passage of lines using PP 2.

(b) Move second in order of movement.

(c) Enter and clear building(s) (*number determined by commander*).

(d) Occupy BP (\_\_\_) and orient on TRP 1.

(3) (\_\_\_) Platoon:

(a) Conduct passage of lines using PP 3.

(b) Move last in order of movement.

(c) Enter and clear building(s) (*number determined by commander*).

(d) Occupy BP (\_\_\_) and orient on TRPs 4 and 5.

(e) Establish an OP vicinity (*grid*).

c. Tasks to Combat Support Units: Engineer squad travels with the company headquarters behind (*evaluated*) Platoon and supports the main effort's emplacement of obstacles.

#### d. Coordinating Instructions.

##### (1) Timings.

- (a) Briefback \_\_\_\_\_.
- (b) Company rehearsal \_\_\_\_\_.
- (c) SP time \_\_\_\_\_.
- (d) In position NLT time \_\_\_\_\_.

(2) Report all enemy contact.

(3) Report crossing all phase lines.

(4) MOPP status \_\_\_\_; enemy chemical attack is expected.

(5) Air defense status is YELLOW, WEAPONS HOLD.

(6) Leaders brief back the movement and defense plan to the commander at the company CP at (*date-time group*).

(7) Destruction of subterranean approaches requires brigade commander's approval.

(8) Selective rubbleing is authorized. Destruction of more than one building requires commander's approval.

(9) Marking of rooms and buildings is IAW CO SOP.

(10) Rules of Engagement are as follows:

- (a) Minimize collateral damage to structures.
- (b) Civilians have been evacuated. Evacuate to company CP any other civilians encountered.

#### 4. SERVICE SUPPORT. IAW the battalion SOP.

##### a. Materiel and Services.

##### (1) Supply.

- (a) Class I. Ration Cycle M-M-M. Platoons must maintain a three-day supply in each BP.
- (b) Class II. Submit requirements for special equipment ASAP. Coordinate with 1SG.
- (c) Class III. Refuel all vehicles before (*date-time group*).
- (d) Class IV. Coordinate with S4 for delivery.
- (e) Class V.

- Platoons cache one additional basic load in BP.
- Platoons submit request for additional demolitions NLT (*date-time group*).

(2) Services. Battalion decontamination site is located vicinity (*grid*).

(3) Maintenance.

(a) Priority to (*evaluated*) Platoon M2 BFVs.

(b) UMCP located vicinity (*grid*).

b. Medical Evacuation and Hospitalization.

(1) Battalion aid station located vicinity (*grid*).

(2) Company CCP located with company CP.

c. Personnel.

(1) No replacements for next 72 to 96 hours.

(2) Brigade mortuary affairs point located in BSA.

(3) EPW collection sites located at (*grid*) for battalion and (*grid*) for company.

d. Miscellaneous.

(1) Battalion trains located vicinity (*grid*).

(2) Company trains located vicinity (*grid*).

## 5. COMMAND AND SIGNAL.

a. Command. Initially, company CP will be traveling center of company wedge. Location in BP to be determined.

b. Signal.

(1) Current SOI in effect.

(2) Primary means of communication in BP is wire, FM, messenger, in that order.

(3) Radio listening silence is in effect until after crossing PL or until contact is made.

ACKNOWLEDGE:

SMITH  
LTC

OFFICIAL:  
SMITH  
S3

---

(Classification)

**Figure E-4. Example OPORD for STX Defend.**

**4. Support Requirements.**

- a. Minimum trainers/evaluators: The company commander or platoon leader serves as the trainer and primary evaluator for this exercise.
- b. Vehicles/communications: All vehicles organic to the platoon should be included.
- c. Opposing force: The OPFOR should be platoon strength.
- d. Maneuver area: A 16-building CTF, a 32-building CTF, or a local MOUT site is required. A training area at least 2 by 10 kilometers is needed for cross-country movement, and a hasty fighting position is desirable. The terrain should offer multiple covered and concealed routes. Using terrain that limits the leader to a geographic or school solution prevents evaluation of the unit's ability to conduct a terrain analysis and to select covered and concealed routes.
- e. Consolidated support requirements: This exercise requires the items shown in Table E-5.

<b>AMMUNITION</b>	<b>DODAC</b>	<b>BASIC LOAD</b>	
5.56-mm	1305A080	150 rounds per rifle 150 rounds per M231 firing port weapon	
7.62-mm	1305A111	600 rounds per 7.62-mm coaxial machine gun	
ATWESS cartridge	1370L367	4 (Viper, for LAW) 7 per Bradley 3 per Dragon	
Hand grenade body, M69	1330G811	2 per rifleman	
Hand grenade fuze (practice)	1330G878	2 per rifleman	
Simulator, projectile, ground burst, M115A2	1370L594	20 per exercise	
Simulator, hand grenade, M116-series	1370L601	6 per vehicle	
<b>OTHER ITEMS</b>			
Batteries			
BA 200 (6-volt)		12 each	
BA 3090 (9-volt)		288 each	
<b>MILES EQUIPMENT</b>	<b>PLATOON</b>	<b>EVALUATORS</b>	<b>OPFOR</b>
M2/M3 set	4		2
M21 blank firing adapter	4		2
M16-series rifle	32		5
Dragon		3	2
Controller gun		2	
Small-arms alignment fixture		1	

**Table E-5. Consolidated support requirements  
for STX defend.**

## 5. Evaluation.

Table E-6 lists the T&EOs from [ARTEP 7-8-MTP](#) used to evaluate this STX.

TASK/FUNCTION	TASK NUMBER
DEFEND MOUT/BUILDING	7-3/4-1118
PERFORM PASSAGE OF LINES	7-3/4-1125
MOVE TACTICALLY	7-3/4-1134

**Table E-6. T&EOs used to evaluate STX defend.**

## **Section II. COMPANY STX/FTXs**

This section provides two example FTXs—an attack FTX for an infantry rifle company, and a defense FTX for a mechanized company or team. Each includes several supporting STXs, which are selected or developed by the company commander. Like the exercises, the sequence of events given for each is an example. The battalion commander, the battalion staff, and the company commanders each make their own training plans for the FTX and the STXs. They base these plans on the battalion and company METLs, local training guidance, their assessment of unit strengths and weaknesses, training priorities, the local readiness posture, and other factors of METT-T. Figure E-5 compares an STX to a small-scale (single mission) company FTX. Figure E-6 compares an STX to a full-scale battalion or brigade FTX.

<b>FTX-1 ATTACK</b>	
<b>STX C-II-1</b>	<b>STX C-II-2</b>
Perform Infiltration/Exfiltration	Perform Cordon and Search
Perform Linkup	Take Action on Contact
Execute an Assault (MOUT)	Perform Infiltration/Exfiltration
Perform Consolidation and Reorganization	Perform Linkup
	Perform Passage of Lines
	Occupy Assembly Area

**Figure E-5. Comparison of STX to small-scale company FTX (conducted and evaluated at company level).**

<b>FTX-2 ATTACK</b>		
<b>STX C-II-3</b>	<b>STX C-II-4</b>	<b>STX C-II-1</b>
<b>DEFEND T&amp;EOs</b>	<b>RETROGRADE T&amp;EOs</b>	<b>ATTACK T&amp;EOs</b>
Prepare for Combat	Develop and Communicate a Plan	Perform Infiltration/Exfiltration
Perform Tactical Road March	Perform Delay	Perform Linkup
Perform Relief Operation	Perform Passage of Lines	Execute an Assault (MOUT)
Defend MOUT/Building	Occupy Assembly Area	Perform Consolidation and Reorganization
	Perform NBC Operations	

**Figure E-6. Comparison of STX to full-scale battalion FTX (conducted and evaluated at battalion level).**

## **INFANTRY RIFLE COMPANY FIELD TRAINING EXERCISE**

### **ATTACK**

#### **1. Objective.**

This example FTX trains the infantry rifle company to conduct offensive operations, with an emphasis on attack missions. It also provides platoons an opportunity to prepare for full-scale FTXs conducted and evaluated by the parent battalion. This exercise provides practice for the company commander, platoon leaders, squad leaders, and company headquarters personnel in planning, coordinating, and controlling combat operations.

#### **2. Interface.**

This FTX is supported by STX C-II-1 and C-II-2 ([Figure E-5](#)). It is also supported by two drills from [ARTEP 7-8-Drill](#): React to Contact and Break Contact.

### 3. Training.

a. Guidance. [ARTEP 7-8-MTP](#) (Chapter 4), [FM 25-100](#), and [FM 25-101](#) provide training guidance, tips, and enhancers for planning and executing STXs. The trainer should review the individual, leader, and collective tasks to be performed during the STX to determine which require initial or refresher training.

b. General situation.

(1) The battalion is ordered to conduct offensive operations in support of the brigade mission. The company is ordered to infiltrate enemy lines and to destroy an insurgent operations base located in the town of McKenna. The company must be prepared to remain in McKenna and conduct cordon and search missions to find and destroy enemy caches of arms and supplies.

(2) This exercise should be conducted under all environmental conditions, especially during limited visibility. The company will move under threat of NBC attack or in an active NBC environment.

c. Special situation.

(1) The battalion commander issues a warning order to prepare for an attack.

(2) The planning process for the attack mission begins when the company receives the battalion warning order. The exercise ends when the company completes a passage of lines, occupies an assembly area, and completes preparations to continue its mission. Figure E-7 shows a graphic scenario of task performance for the FTX Attack. Table E-7 provides a recommended sequence of T&EOs from [ARTEP 7-8-MTP](#) and the time allotted for each portion of the STX.

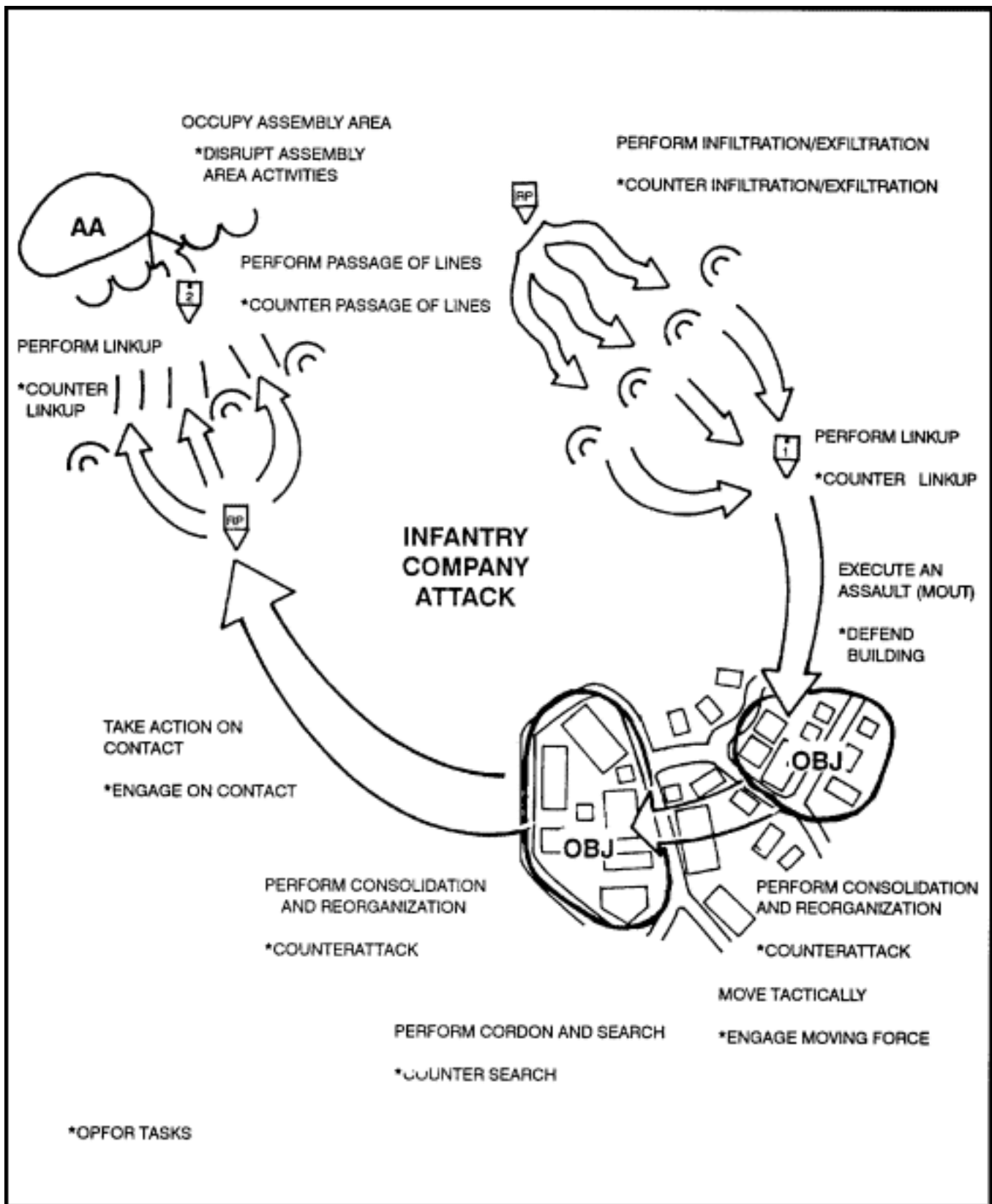

**Figure E-7. Graphic scenario of task performance for FTX Attack.**

(3) The battalion commander issues an OPORD to the company (Figure E-8).

EVENT	ACTION	ESTIMATED TIME*
<b>START STX C-II-1</b>		
1	Issue Company OPORD	4 hr
2	Perform Infiltration/ Exfiltration	6 hr
3	Perform Linkup	3 hr
4	Execute an Assault (MOUT)	6 hr AAR
5	Perform Consolidation and Reorganization	3 hr
<b>ISSUE FRAGO, START STX C-II-2</b>		
6	Perform Cordon and Search	6 hr
7	Take Action on Contact	3 hr
8	Perform Infiltration/Exfiltration	6 hr
9	Perform Linkup	3 hr AAR
10	Perform Passage of Lines	2 hr
11	Occupy Assembly Area	3 hr
12	Conduct Final AAR	2 hr
	<b>*** TOTAL TIME</b>	<b>47 hr</b>
<p>** Prepare for Combat</p> <p>** Maintain Operations Security</p> <p>** Move Tactically</p> <p>** Perform Consolidation and Reorganization</p>		
<p>* The time required to train an event varies, based on the factors of METT-T and on the unit's training proficiency. Regardless, training is conducted to standards, not to time limitations.</p> <p>** These tasks are integrated and evaluated throughout the exercise.</p> <p>*** Time for intermediate AARs is not included in this total; additional time is required if much of the exercise is conducted at night or during other limited visibility.</p>		

**Table E-7. Sequence of events and times for FTX Attack.**

**Figure E-8. Example battalion OPORD for FTX Attack (continued).**

---

 (Classification)

Copy no \_\_\_ of \_\_\_ copies  
 \_\_\_ Battalion, \_\_\_ Infantry  
 Unit location or place of issue  
 Date-time group (with time zone)  
 Message reference number

OPERATION ORDER NO. \_\_\_

References: Map, series no. \_\_\_, sheet no. \_\_\_, edition \_\_\_

Time Zone Used Throughout the Order: \_\_\_

TASK ORGANIZATION:

\_\_\_ Company \_\_\_ Company \_\_\_ Company

Battalion Control  
 Scout Platoon  
 81-mm Mortar Platoon  
 Antitank Platoon  
 1/C/58th ENGR (DS)  
 Battalion Trains

## 1. SITUATION.

a. Enemy Forces. See ANNEX A (intelligence overlay [prepared by brigade S2]).

(1) Composition, Disposition, and Strength. The battalion is opposed by one company from the Dona Anna Militia Guards Battalion. This enemy company consists of 3 platoons with 35 to 40 soldiers equipped with M16s, AK-47s, and light machine guns. Their company headquarters is located in the town hall of McKenna. The company itself is at 90 percent strength and has indirect fire support assets available.

(2) Capabilities. The enemy possesses nonpersistent nerve agents and indirect fire assets capable of delivery. He also has some light armored vehicles in the area, but their location is undetermined. No enemy air threat exists. However, the enemy may be able to reinforce McKenna with an additional company within two hours.

(3) Probable course of action. The enemy will defend McKenna and continue using it as a base of operations and to consolidate weapons and material. His intent is to prevent capture of McKenna and the support base, provided by its facilities and population.

b. Friendly Forces.

(1) (\_\_\_) Brigade, (\_\_\_) Division attacks at (*date-time group*) to seize the town of McKenna at (*grid*), to keep the enemy from using it as a base of operations. The intent

is to secure the town and the road network in the area, to prevent the enemy from using it as a base of operations.

(2) (\_\_\_\_) Battalion, (\_\_\_\_) Infantry attacks to seize the road network at OBJ (\_\_\_\_), vicinity (*grid*), at (*date-time group*) to prevent enemy forces from counterattacking along Route (\_\_\_\_).

(3) (\_\_\_\_) Battalion, (\_\_\_\_) Infantry attacks at (*date-time group*), to seize the high ground at OBJ (\_\_\_\_), vicinity (*grid*), and to establish defensive positions to block enemy routes in and out of McKenna.

2. MISSION. (\_\_\_\_) Battalion, (\_\_\_\_) Infantry attacks at (*date-time group*) to seize McKenna, vicinity (*grid*), NLT (*date-time group*), to prevent the enemy from using the town as an operations and logistics base.

### 3. EXECUTION.

a. Concept of the Operation. See ANNEX B (operations overlay). The battalion will accomplish its mission, which is to deny the enemy use of McKenna and its surrounding terrain and population, by seizing the town and controlling the key areas in the vicinity. We will conduct a feint in the west and then attack the decisive point within McKenna (OBJ [\_\_\_\_]).

(1) Maneuver. (\_\_\_\_) Company will conduct a feint to deceive the enemy, then the main effort (*evaluated*). Company will seize OBJ (\_\_\_\_) to prevent the enemy from using McKenna as an operational and logistical base.

(\_\_\_\_) Company will support the main effort by seizing OBJ (\_\_\_\_), in order to prevent the enemy from counterattacking the main effort. (\_\_\_\_) Company will seize OBJ (\_\_\_\_) to support the main effort's attack.

(2) Fire Support. See ANNEX C. Purpose of fires is to suppress the enemy and to obscure movement to McKenna. Priority of artillery fires is to (*feinting*) Company; on order, priority will shift to (*supporting effort*) Company. Priority of 81-mm mortar fires is to (*evaluated*) Company.

(3) Engineering. The purpose of the engineers is to breach obstacles during the attack in order to help (*evaluated*) Company seize OBJ (\_\_\_\_). Priority of support is to (*evaluated*) Company, (\_\_\_\_) Company, and (\_\_\_\_) Company, in that order. The battalion commander must authorize any booby traps, and any point and hasty minefields.

b. Tasks to Maneuver Units.

(1) (*Evaluated*) Company.

(a) Infiltrate using infiltration lane TANGO.

(b) Seize OBJ (\_\_\_\_) vicinity (*grid*) NLT (*date-time group*).

(c) Be prepared to perform cordon and search of McKenna, after consolidation

and reorganization.

(2) (*Supporting*) Company.

- (a) Follow (*main attack*) Company and infiltrate on infiltration lane TANGO.
- (b) Seize OBJ (\_\_\_) vicinity (*grid*) NLT (*date-time group*).
- (c) Coordinate the attack with (*evaluated*) Company, so that both units attack at the same time.
- (d) Be prepared to perform cordon and search in the objective area after consolidation and reorganization.
- (e) Be prepared to assume the mission of (*evaluated*) Company.

(3) (*Supporting*) Company.

- (a) Infiltrate using infiltration lane ZEBRA.
- (b) Conduct feint to OBJ (\_\_\_), vicinity (*grid*), NLT (*date-time group*).
- (c) Be prepared to establish defensive positions vicinity (*grid*) to prevent enemy movement to and from McKenna.

c. Tasks to Combat Support Units.

(1) Scout Platoon.

- (a) During movement, determine location, strength, and disposition of enemy forces in McKenna.
- (b) On order, screen the battalion flank from (*grid*) to (*grid*) to warn of the approach of enemy units from the southwest.

(2) Mortar Platoon. Priority of mortar fire is to (*evaluated*) Company. Mortar platoon moves with (*evaluated*) Company, establishes a firing position vicinity (*grid*), and displaces on order.

(3) Antitank Platoon.

- (a) Initially, overwatch from (*grid*) to (*grid*) to secure the unit infiltration.
- (b) On order, move vicinity (*grid*) to support (*evaluated*) Company's consolidation and reorganization.

(4) 1/C/58 Engineers.

- (a) Move with (*evaluated*) Company to provide mobility support.
- (b) Be prepared to reduce obstacles in McKenna during cordon and search mission.

d. Coordinating Instructions.

- (1) Report when ready to execute assault.
- (2) Report any movement of enemy forces from the southwest.
- (3) No rubble is authorized, so minimize collateral damage to property.
- (4) MOPPO is in effect.
- (5) Terrorist threat warning is red.
- (6) Commanders briefback OPORD to battalion commander at battalion tactical CP at (*date-time group*).
- (7) Rules of Engagement (ROE).
  - (a) Commanders will take all steps necessary and appropriate for their units' protection.
  - (b) The minimum necessary force will be used to control the situation.
  - (c) Leaders must take measures to minimize risk to civilians, without endangering the unit.
  - (d) Fire is returned directly to its source, not sprayed into a general area.
  - (e) Firing ceases when the threat is over.
  - (f) Anyone trying to surrender is allowed to do so.
  - (g) Civilians and property are treated with respect.
  - (h) WP can be used vicinity McKenna to aid in isolating the objectives. Requests for indirect fire within the town must be authorized by the battalion commander.

4. SERVICE SUPPORT. See Annex D.

5. COMMAND AND SIGNAL.

a. Command.

- (1) The tactical CP will move with (*evaluated*) Company.
- (2) The main CP is vicinity (*grid*) and will displace on order.
- (3) The second in command remains in the battalion main CP.
- (4) The rear CP is the alternate battalion main CP.

b. Signal.

- (1) Current SOI is in effect.
- (2) Radio-listening silence is in effect for all elements except scouts, until prepared to attack.

ACKNOWLEDGE:

SMITH  
LTC

OFFICIAL:  
SMITH  
S3

Annexes:

A - Intelligence Overlay  
B - Operations Overlay  
C - Fire Support  
D - Service Support

---

(Classification)

**Figure E-8. Example battalion OPORD  
for FTX Attack (continued).**

(4) The battalion has destroyed the enemy operating in McKenna and seized the town. Two companies are conducting consolidation and reorganization in McKenna and defending against a limited counterattack. One company is in a blocking position to the southwest of town. A cordon and search should be performed to locate any enemy personnel or equipment remaining in McKenna. The evaluated company receives the FRAGO shown in Figure E-9.

Enemy personnel in squad-size elements are reported by the civilian population to be hiding in McKenna. Reports also indicate numerous weapons caches are being hidden by civilians collaborating with the enemy. Battalion has completed its mission and is preparing to conduct a cordon and search. After completing this, the battalion will exfiltrate to perform a passage of friendly lines. (*Evaluated*) Company moves to perform cordon and search vicinity OBJ (\_\_\_), beginning (*date-time group*) to (*date-time group*), to locate and seize enemy personnel or equipment. The (*evaluated*) Company notifies the commander of the results of the search and when they are ready to start movement. They exfiltrate on order along Route Gold to perform linkup at (*grid*) and passage of lines at (*grid*). (*See overlay for lanes.*)

**Figure E-9. Example FRAGO for FTX Attack.****4. Support Requirements.**

- a. **Minimum trainers/evaluators:** The company commander serves as the trainer or primary evaluator for this exercise. The battalion may direct the FTX internal evaluation along with a company evaluator and an FO evaluator. The platoon leaders and platoon sergeants are the primary trainers during the initial phases of the training. The company commander, the XO, the platoon leaders, and the platoon sergeants all act as trainers during the company phases of training. When an exercise is conducted by the battalion, either the battalion commander, XO, or S3 acts as the trainer and evaluator; additional battalion assets may be required to support the evaluation phase. The controllers or evaluators must be positioned at critical locations throughout the exercise to observe the action. They must not interfere with the conduct of the operation, except to halt it when a safety violation occurs or to conduct an AAR.
- b. **Vehicles/communications:** Those organic to the company are used in the exercise. This includes one designated medical evacuation vehicle for each platoon and at least one aidman on site.
- c. **Opposing force:** The OPFOR ground force should be at least platoon-size. FTXs conducted by the company require internal resourcing; units should rotate to ensure total training. OPFOR tasks and standards are provided in each T&EO.
- d. **Maneuver area:** A training area at least 5 by 10 kilometers is best for this exercise.
- e. **Consolidated support requirements:** This exercise requires the items shown in Table E-8.

<b>AMMUNITION</b>	<b>DODAC</b>	<b>BASIC LOAD</b>	
5.56-mm	1305A080	120 rounds per rifle	
5.56-mm	1305A075	600 rounds per M249 LMG	
ATWESS cartridge	1370L367	6 (Viper, for LAW) 4 per Bradley 4 per Dragon	
Hand grenade body, M69	1330G811	4 per rifleman	
Hand grenade fuze (practice)	1330G878	4 per rifleman	
Simulator, projectile, ground burst, M1 15A2	1370L594	30 per exercise	
Simulator, hand grenade, M1 16-series	1370L601	30 per vehicle	
<b>OTHER ITEMS</b>			
Batteries			
BA 200 (6-volt)		24 each	
BA 3090 (9-volt)		400 each	
<b>MILES EQUIPMENT</b>	<b>PLATOON</b>	<b>EVALUATORS</b>	<b>OPFOR</b>
M 1 6-series rifle	124		30
M249 LMG System	18		6
Controller gun		3	1
Small-arms alignment fixture		3	1

**Table E-8. Consolidated support requirements for FTX Attack.**

## 5. Evaluation.

Table E-9 lists the ARTEP mission training plan T&EOs used to evaluate this STX.

TASK/FUNCTION	TASK NUMBER
<b>ARTEP 7-8-MTP</b>	
TAKE ACTION ON CONTACT	7-3/4-1107
PERFORM PASSAGE OF LINES	7-3/4-1125
PERFORM LINKUP	7-3/4-1128
MOVE TACTICALLY	7-3/4-1134
OCCUPY ASSEMBLY AREA	7-3/4-1136
MAINTAIN OPERATIONS SECURITY	7-3/4-1409
PREPARE FOR COMBAT	7-3/4-1606
PERFORM CONSOLIDATION AND REORGANIZATION	7-3/4-1607
<b>ARTEP 7-10-MTP</b>	
PERFORM CORDON AND SEARCH	7-2-1105
EXECUTE AN ASSAULT (MOUT)	7-2-1109
<b>ARTEP 7-20-MTP</b>	
PERFORM EXFILTRATION	7-1-1146
PERFORM INFILTRATION	7-1-1147
PERFORM REORGANIZATION	7-1-1608
PERFORM CONSOLIDATION	7-1-1609

**Table E-9. T&EOs used to evaluate FTX Attack.**

**MECHANIZED COMPANY OR TEAM  
FIELD TRAINING EXERCISE**

**DEFEND**

**1. Objective.**

This example FTX trains the mechanized infantry company or team to conduct defensive operations in MOUT. It also provides platoons an opportunity to prepare for full-scale FTXs conducted and evaluated by the parent battalion. This exercise provides practice for the company commander, platoon leaders, squad leaders, and company headquarters personnel in planning, coordinating, and controlling combat operations.

## 2. Interface.

This FTX is supported by the STX C-II-5 and C-II-6 tasks shown in Figure E-10. It is also supported by two drills from [ARTEP 7-8-Drill](#): React to Contact and Break Contact.

FTX-3 DEFENSE	
STX C-II-5	STX C-II-6
Occupy Assembly Area	Perform Ambush
Perform Tactical Road March	Establish a Roadblock/Checkpoint
Perform Relief Operations	Perform NBC Operations
Defend MOUT/Building	Move Tactically
	Perform Passage of Lines
	Occupy Assembly Area

**Figure E-10. Supporting tasks for company FTX.**

## 3. Training.

a. Guidance. [ARTEP 7-8-MTP](#) (Chapter 4), [FM 25-100](#), and [FM 25-101](#) provide training guidance, tips, and enhancers for planning and executing STXs. The trainer should review the individual, leader, and collective tasks to be performed during the STX to determine which require initial or refresher training.

b. General situation.

(1) The battalion is ordered to conduct defensive operations in support of the brigade mission; the company is ordered to perform a relief operation and to prepare a defense in an urban area. The company will remain in position for at least 36 hours before receiving a follow-on mission. Most civilians have been evacuated from the area, but a few remain. A terrorist threat exists as well as the possibility of enemy battalion-level offensive actions.

(2) This exercise should be conducted under all environmental conditions, especially during

limited visibility. The company will also conduct operations under threat of NBC attack.

c. Special situation.

(1) The planning process for the defense mission begins when the company receives a warning order. The exercise ends when the company completes the passage of lines and occupies an assembly area. Figure E-11 shows a graphic scenario of task performance for the FTX Defend. Table E-10 provides a recommended sequence of T&EOs from [ARTEP 7-8 MTP](#) and the time allotted for each portion of the STX.

(2) The battalion commander issues the defense OPORD to the company (Figure E-12).

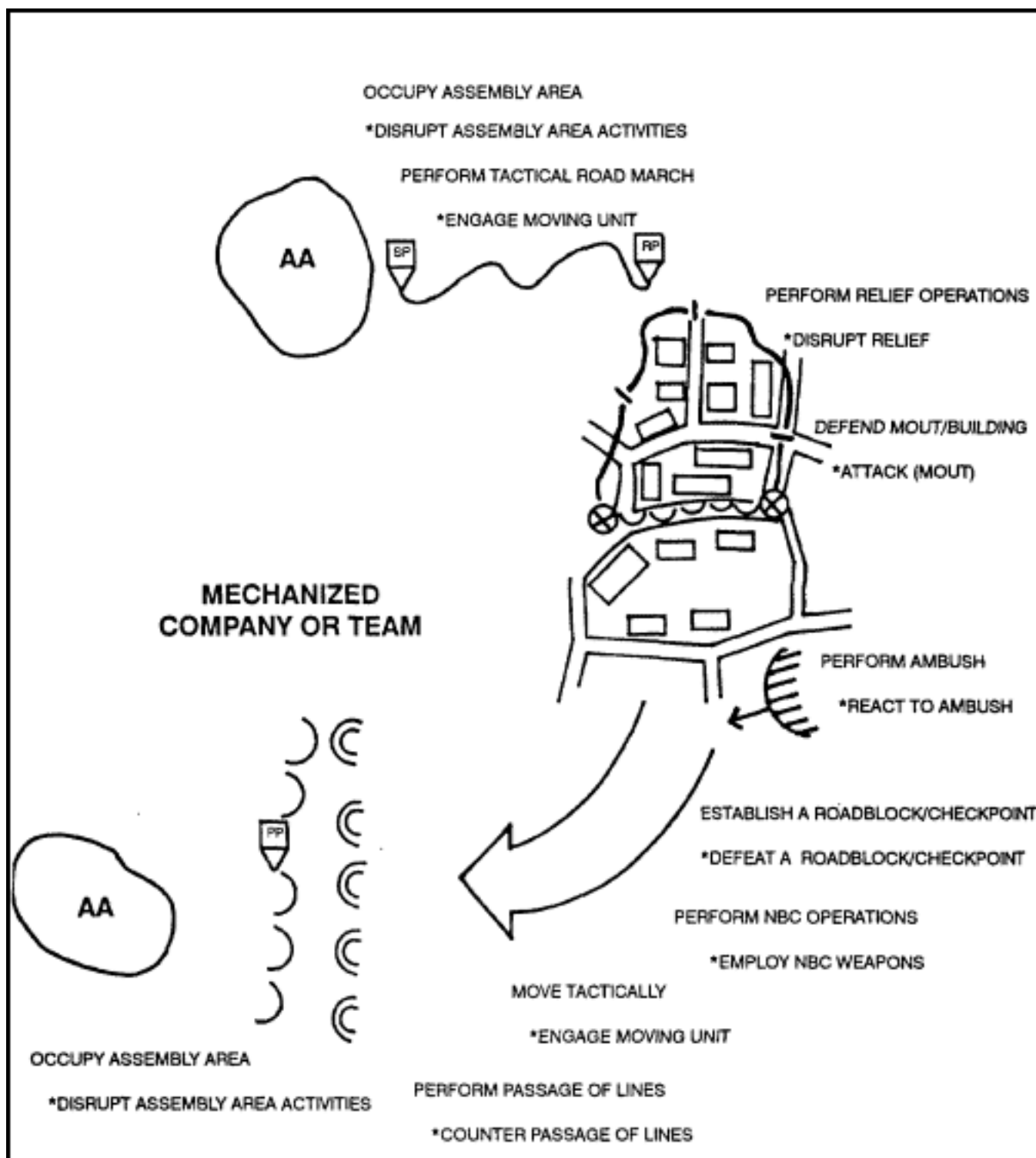

\*OPFOR TASKS

**Figure E-11. Graphic scenario of task performance  
for FTX Defend.**

EVENT	ACTION	ESTIMATED TIME*
<b>START STX C-II-5</b>		
1	Occupy Assembly Area	2 hr
2	Issue Company OPORD	4 hr
3	Perform Tactical Road March	3 hr
4	Perform Relief Operations	6 hr AAR
5	Defend MOUT/Building	24 hr
<b>ISSUE FRAGO, START STX C-II-6</b>		
6	Perform Ambush	6 hr
7	Establish a Roadblock/Checkpoint	6 hr AAR
8	Perform NBC Operations	6 hr
9	Move Tactically	3 hr
10	Perform Passage of Lines	2 hr
11	Occupy Assembly Area	3 hr
12	Conduct Final AAR	2 hr
	<b>*** TOTAL TIME</b>	<b>67 hr</b>
**	Prepare for Combat	
**	Maintain Operations Security	
**	Move Tactically	
**	Perform Consolidation and Reorganization	
<p>* The time required to train an event varies, based on the factors of METT-T and on the unit's training proficiency. Regardless, training is conducted to standards, not to time limitations.</p> <p>** These tasks are integrated and evaluated throughout the exercise.</p>		

\*\*\* Time for intermediate AARs is not included in this total; additional time is required if much of the exercise is conducted at night or during other limited visibility.

**Table E-10. Sequence of events and times for FTX Defend.**

**Figure E-12. Example battalion OPORD for FTX Defend.**

(Classification)

Copy no \_\_\_\_ of \_\_\_\_ copies  
 \_\_\_\_ Battalion, \_\_\_\_ Infantry  
 Unit location or place of issue  
 Date-time group (with time zone)  
 Message reference number

OPERATION ORDER NO. \_\_\_\_

References: Map, series no. \_\_\_\_, sheet no. \_\_\_\_, edition \_\_\_\_

Time Zone Used Throughout the Order: \_\_\_\_

TASK ORGANIZATION:

\_\_ Company

\_\_ Team

Team (-)

Battalion Control

1/\_/\_/AR

2/\_/\_/AR

Scout Platoon

120-mm Mortar Platoon

1/C/1-222 ADA (Stinger)

(DS)

C/58 ENGR (DS)

1/1 (GSR) TM A/58 MI

Bn

CATK Force B

(1/\_/\_/Infantry)

Battalion Trains

Team Tank

E Co (-)

1/\_/\_/Infantry

2/\_/\_/Infantry

## 1. SITUATION.

a. Enemy Forces. See ANNEX A (intelligence overlay [prepared by brigade S2]).

(1) Composition, Disposition, and Strength. The company is opposed by the 118th Regiment of the 3d Motorized Rifle Division. This regiment is at 85 percent strength and has received engineer and artillery reinforcements. The enemy is equipped with T-62 tanks, BTR-60s, and BMP-1s.

(2) Capabilities. The enemy has established defensive positions that follow a line from vicinity (*grid*) to (*grid*). Enemy armored reconnaissance units are operating in the more open terrain southwest of McKenna. The enemy has been observed moving forces in depth throughout the area in preparation for an offensive action.

(3) Probable Course of Action. The enemy's most probable course of action will be to begin offensive actions within the next 24 to 36 hours. Enemy encountered will include numerous reconnaissance elements trying to find the company's vulnerabilities and a main body trying to exploit any weakness.

b. Friendly Forces.

(1) (\_\_\_) Brigade, (\_\_\_) Division relieves (\_\_\_) Brigade in place at (*date-time group*), to defend in sector from (*grid*) to (*grid*) to (*grid*) to (*grid*), in order to secure the corps counterattack axis of advance, (*grid*). The intent is to secure the road network around McKenna and prevent the enemy from impeding the movement of (\_\_\_) Brigade, (\_\_\_) Division.

(2) (\_\_\_) TF is the main effort in the defense and, NLT (*date-time group*), holds key terrain vicinity (*grid*) on Our left, to prevent an enemy bypass of the brigade left flank.

(3) (\_\_\_) TF, on our right, defends along Route 360, vicinity (*grid*) to (*grid*) to (*grid*) to (*grid*), NLT (*date-time group*), to prevent an envelopment of the right flank. The TF conducts a supporting attack at (*date-time group*) to seize the high ground at OBJ OAK, vicinity (*grid*), to establish defensive positions that will prevent the enemy armored reconnaissance units from interfering with the seizure of the pass at (*grid*) or the attack of the Battalion, (\_\_\_) Infantry, Mechanized.

2. MISSION. (\_\_\_) TF defends NLT (*date-time group*), to retain the town of McKenna and its surrounding road network and allow brigade to prevent enemy interference with corps counterattack.

3. EXECUTION.

a. Concept of the Operation. See ANNEX B (operations overlay).

(1) Maneuver. Company (*main effort*) retains the main intersection (traffic loop) in McKenna to prevent enemy movement through the sector. (*Evaluated*) Team blocks movement west of 3d Street to prevent the enemy from enveloping the main effort. The CATK force will be committed as needed.

(\_\_\_) Team will block movement east of Oak Street to canalize the enemy into EA (\_\_\_). (\_\_\_) Team will defend from BPI to prevent a coordinated attack against the main effort. E Company occupies BPs to destroy enemy vehicles and protect the TF flanks.

(2) Fire Support. See ANNEX C. Fires will be used to suppress the enemy and obscure our movement during the relief operation. Once positions are occupied, fires will be used to suppress enemy overwatch positions, disrupt attempts to breach obstacles, and separate enemy infantry from their supporting carriers. Priority of CAS and indirect fire is initially to (*evaluated*) Team during the relief operation, then to (*main effort*) Team. (*Main effort*) and (*evaluated*) Teams each have two priority 155-mm targets. Each team may make one priority target an FPF.

(3) Counterair Operations. Priority of protection is to the TF trains and main CP Air

defense weapons status is free; air defense warning status is yellow.

(4) Intelligence. Priority of collection is to identify and locate the C2 elements of the MRR and MRB, enemy tank battalions, and the enemy assault detachments' actual axes of advance.

(5) Engineering. The purpose of obstacles is to turn the enemy into restrictive terrain and engagement areas. Priority of support is to (*main effort*) Team, (*evaluated*) Team, (\_\_\_) Team, and (\_\_\_) Team, in that order.

b. Tasks to Maneuver Units.

(1) (*Main effort*) Team.

(a) Sector of defense includes the east side of Front Street, the south side of 1st Street, the west side of 3d Avenue -area, and the north side of 3d Street.

(b) (*Main effort*) Team relieves (\_\_\_) Team, (\_\_\_) TF.

(2) (*Evaluated*) Team.

(a) Sector includes the east side of 3d Avenue, the south side of 1st Street, the west side of 6th Avenue, and the north side of 3d Street.

(b) (*Evaluated*) Team relieves (\_\_\_) Team, (\_\_\_) TF.

(3) (\_\_\_) Team.

(a) Sector includes the east side of Oak Street, the south side of 1st Street, the east side of Front Street, and the north side of 3d Street.

(b) Team relieves (\_\_\_) Team, (\_\_\_) TF.

(c) Team coordinates directly with right flank team of TF to ensure mutually supporting fires.

(4) (\_\_\_) Team.

(a) Occupy BP I vicinity (*grid*).

(b) Be prepared to occupy BP 2 (*grid*) to engage enemy in EA (\_\_\_).

(5) Company E.

(a) Occupy BP 2-1 (*grid*) and move on order to BP 2-2 (*grid*).

(b) Provide antiarmor fires to destroy enemy tanks in EA (\_\_\_).

(6) CATK B (reserve).

(a) Occupy AA Black, vicinity (*grid*).

(b) Reconnoiter routes into (*main effort*) TF sector.

## (c) Priority for planning:

- 1 Battle plan to reinforce main effort.
- 2 Battle plan to counterattack into (*main effort*) Team sector.
- 3 Battle plan to counterattack into (*evaluated*) Team sector.

## (7) Scout Platoon.

- (a) Determine location, strength, and disposition of enemy forces.
- (b) Perform a screen of the TF's right flank from (*grid*) to (*grid*), beginning (*date-time group*), to prevent enemy infiltration of McKenna.

## c. Tasks to Combat Support Units.

## (1) Mortar Platoon.

- (a) Priority of fire to (*main effort*) TF. Move with (*main effort*) TF and establish firing position vicinity (*grid*).
- (b) Displace on order to (*grid*).

(2) 1/C/1-222ADA. Coordinate locations with S3 NLT (*date-time group*).

## (3) C/58 Engineers.

- (a) Coordinate the engineer effort with the team commanders NLT (*date-time group*).
- (b) Provide an obstacle clearing team to CATK Force B, NLT (*date-time group*).

(4) 1/1 (GSR) TM A/58 MI. Coordinate location of assets with the task force S3 NLT (*date-time group*).

## d. Coordinating Instructions.

- (1) Selective rubbleing is authorized, but destruction of more than one building requires TF commander approval.
- (2) Destruction of subterranean approaches requires TF commander approval.
- (3) Commanders briefback OPORD to TF commander at the TF tactical CP, vicinity (*grid*), at (*date-time group*).
- (4) MOPP1 is in effect as of (*date-time group*).
- (5) Decontamination site is established vicinity Miller Pond (*grid*).

## 4. SERVICE SUPPORT. See Annex D.

## a. Materiel and Services.

## (1) Supply.

(a) Class I. Ration cycle C-A-C. Team will establish MRE cache sufficient for 48 hours in sector.

(b) Class III. Resupply available on request. Class III located in combat trains.

(c) Class IV. Materials are allocated as shown in ANNEX D.

(d) Class V. Each team will establish ammunition caches in sector, but should also have two basic loads of ammunition on hand.

(2) Transportation. The main streets are capable of two-way heavy vehicle traffic (*class 60*). Secondary streets may be one way and of lighter construction (*class 50*).

(3) Maintenance.

(a) Priority by unit: (*main effort*) Team, (*evaluated*) Team, (\_\_\_) Team, Company E, (\_\_\_) Team.

(b) Priority by vehicle: M1A1, M2/M3, M113.

b. Medical Evacuation and Hospitalization.

(1) TF aid station located vicinity (*grid*).

(2) Civilian casualties should be transported by nonmilitary means to clinic, vicinity (*grid*).

c. Personnel.

(1) No replacements for the next 96 hours.

(2) EPW collection point located vicinity (*grid*).

(3) Mortuary affairs point located in BSA, vicinity (*grid*).

d. Civil-Military Cooperation.

(1) Curfew in effect from 1800 to 0800 daily.

(2) Most civilians have been evacuated. Those remaining have been notified of the risk involved.

e. Miscellaneous.

(1) Combat trains are located vicinity (*grid*).

(2) Field trains are located in the BSA, vicinity (*grid*).

## 5. COMMAND AND SIGNAL.

a. Command.

(1) Brigade main CP located vicinity (*grid*).

(2) TF tactical CP located vicinity (*grid*).

- (3) TF main CP located vicinity (*grid*).
- (4) TF commander located at tactical CP.
- (5) TF XO located at Main CP,

b. Signal.

- (1) SOI INDEX 1-9 in effect.
- (2) Primary means of communication is wire, FM, messenger in that order.
- (3) Building and obstacle marking IAW TF SOP.

ACKNOWLEDGE:

WILLIAMS  
LTC

OFFICIAL:

SMITH  
S3

Annexes: A

- A - Intelligence Overlay
- B - Operations Overlay
- C - Fire Support
- D - Service Support

---

(Classification)

**Figure E-12. Example battalion OPORD for FTX Defend.**

(4) The TF has retained the north half of McKenna after the enemy attack. The enemy was defeated but has established squad-size to platoon-size strongpoints in the southern half of McKenna. The enemy is expected to receive reinforcements within the next 12 to 24 hours. To prevent enemy reinforcements from moving to the strongpoints to strengthen and resupply them, TF headquarters orders the team to conduct platoon-size ambushes. They also order the team to prepare to establish a roadblock to control refugee flow through the area of operations, before the team moves out of the area. Headquarters issues a FRAGO ([Figure E-13](#)).

**4. Support Requirements.**

a. Minimum trainers/evaluators: The company commander serves as the trainer or primary evaluator for this exercise. The battalion may direct the FTX internal evaluation using a company evaluator and an FO evaluator.

The platoon leaders and platoon sergeants are the primary trainers during the initial phases of the training. The company commander, the XO, the platoon leaders, and the platoon sergeants act as trainers during the company phases of training. When an exercise is conducted by the battalion, either the battalion commander, the XO, or the S3 acts as the trainer and evaluator, and may require additional assets from the battalion to support the evaluation phase. The controllers or evaluators must be positioned at critical locations throughout the exercise to observe the action. They must not interfere with the conduct of the operation, except to halt it when a safety violation occurs or to conduct an AAR.

Numerous enemy strongpoints are located to your front, vicinity (*grid*), (*grid*), and (*grid*). We expect these strongpoints to receive reinforcements within the next 12 to 24 hours. Your mission is to establish platoon ambushes on the likely avenues of approach to the strongpoints, NLT (*date-time group*), in order to prevent reinforcements or resupply to these strongpoints. Notify the TF commander when you are prepared to move. Coordinate with TF scouts for guides. On order, after return from ambush missions, establish roadblocks at (*grid*) and (*grid*). Be prepared to move within the next 36 to 48 hours to conduct further follow-on missions.

**Figure E-13. Example FRAGO for FTX Defend.**

b. Vehicles/communications: Those organic to the company are used.

c. Opposing force: The OPFOR ground force should be at least platoon-size. FTXs conducted by the company require internal resourcing, and units should be rotated to ensure total training. T&EOs provide training tasks and standards for the OPFOR.

d. Maneuver area: A training area at least 5 by 15 kilometers is best for this exercise.

e. Consolidated support requirements: This exercise requires the items shown in Table E- 11.

<b>AMMUNITION</b>	<b>DODAC</b>	<b>BASIC LOAD</b>	
5.56-mm	130SA080	200 rounds per rifle	
5.56-mm	1305A075	600 rounds per M249 LMG	
7.62-mm	1305A111	600 rounds per BFV	
ATWESS cartridge	1370L367	6 (Viper, for LAW) 4 per Dragon 4 per M2 BFV	
Hand grenade body, M69	1330G811	4 per rifleman	
Hand grenade fuze (practice)	1330G878	4 per rifleman	
Simulator, projectile, ground burst, M115A2	1370L594	30 per exercise	
Simulator, hand grenade, M116-series	1370L601	30 per vehicle	
<b>OTHER ITEMS</b>			
Batteries			
BA 200 (6-volt)		24 each	
BA 3090 (9-volt)		400 each	
<b>MILES EQUIPMENT</b>	<b>PLATOON</b>	<b>EVALUATORS</b>	<b>OPFOR</b>
M16-series rifle	92		32
M249 LMG system	18		6
M2A2 BFV system	9		4
M1A1 Tank system	4		
M113 APC	2		
Controller gun		3	1
Small-arms alignment fixture		3	1

**Figure E-11. Consolidated support requirements for FTX Defend.**

## 5. Evaluation.

Table E-12 lists the ARTEP mission training plan T&EOs used to evaluate this STX.

TASK/FUNCTION	TASK NUMBER
<b>ARTEP 7-8-MTP</b>	
DEFEND MOUT/BUILDING	7-3/4-1118
PERFORM TACTICAL ROAD MARCH	7-3-1123
PERFORM RELIEF OPERATIONS	7-3/4-1124
PERFORM PASSAGE OF LINES	7-3/4-1125
MOVE TACTICALLY	7-3/4-1134
OCCUPY ASSEMBLY AREA	7-3/4-1136
ESTABLISH A ROADBLOCK/CHECKPOINT	7-3/4-1401
PERFORM NBC OPERATIONS	7-3/4-1406
MAINTAIN OPERATIONS SECURITY	7-3/4-1409
PREPARE FOR COMBAT	7-3/4-1606
PERFORM CONSOLIDATION AND REORGANIZATION	7-3/4-1607
<b>ARTEP 7-10-MTP</b>	
PERFORM AMBUSH	7-2-1145

**Table E-12. T&EOs used to evaluate FTX Defend.**

## APPENDIX F EXAMPLE TRAINING PLAN

*Sound MOUT training begins with a sound plan. Training plans are prepared IAW [FM 25-101](#), which states that "Planning links the unit METL and the execution of battle-focused training." The commander begins his planning with guidance from a higher echelon and an in-depth assessment of METL tasks (in this case, mission-essential MOUT tasks). Based on his own observations and on feedback from his subordinates and other sources, the commander determines which tasks should be trained, which should be trained first, and how much time should be allotted for each. This appendix provides an example of this process applied to an infantry battalion preparing for a MOUT mission. In the example, a six-week, five-phase training plan culminates with two weeks of STX, LFX, and FTX training.*

### F-1. LONG-RANGE PLAN

Figure F-1 shows the long-range training calendar for the battalion, including the example training plan provided in this appendix.

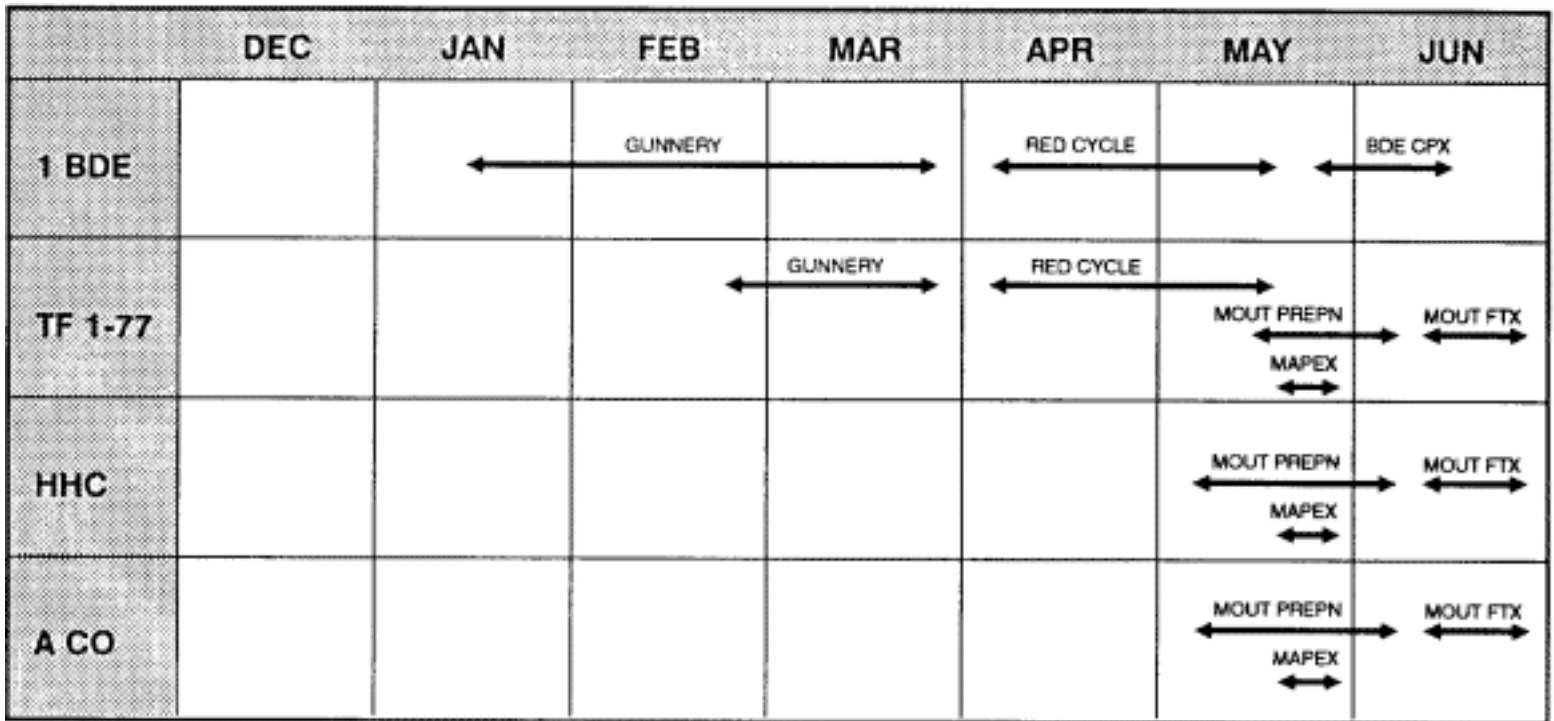

**Figure F-1. Long-range training calendar.**

### F-2. SHORT-RANGE PLAN

The following aspects of short-range planning are specific to MOUT ([Figure F-2](#) shows an example short-range training calendar):

- a. **Risk Assessment.** Fighting in a built-up area has inherent risks. The commander must make

training decisions and implement controls to avoid risk to the soldiers.

**b. Multiechelon and Combined Arms Training.** The specialty platoons must learn techniques for operating in built-up areas. Therefore, instead of supporting training, they must participate in it.

- (1) Scout tasks include reconnoitering, patrolling, conducting a surveillance, and screening in a built-up area.
- (2) Mortar platoon tasks include selecting and camouflaging a mortar firing position in a built-up area, firing a mortar from a hard-surfaced firing position, and making the best use of munition effects.
- (3) Antiarmor company and platoon tasks include providing antiarmor fire, screening, and preparing a TOW position in a built-up area.
- (4) Communications platoon tasks include retransmitting radio communications and sending communications by wire in a built-up area, because normal radio transmissions are likely to be erratic.
- (5) Medical platoon tasks include establishing triages and evacuating soldiers from a built-up area.
- (6) Support platoon tasks include establishing a site from which to conduct support operations in a MOUT environment and transporting cargo and supplies in a rubble area.
- (7) Maintenance platoon tasks include selecting and establishing a UMCP or field maintenance sites in a built-up area and recovering vehicles from a rubble area.

**c. Training Aids and Devices.** Useful audiovisual training aids may be obtained from local TSCs. The commander can select from these and can also use appropriate training devices to help soldiers learn to fight in built-up areas. Other devices especially useful in MOUT training are MILES, training grenades, and locally produced grappling hooks, ladders, and booby traps.

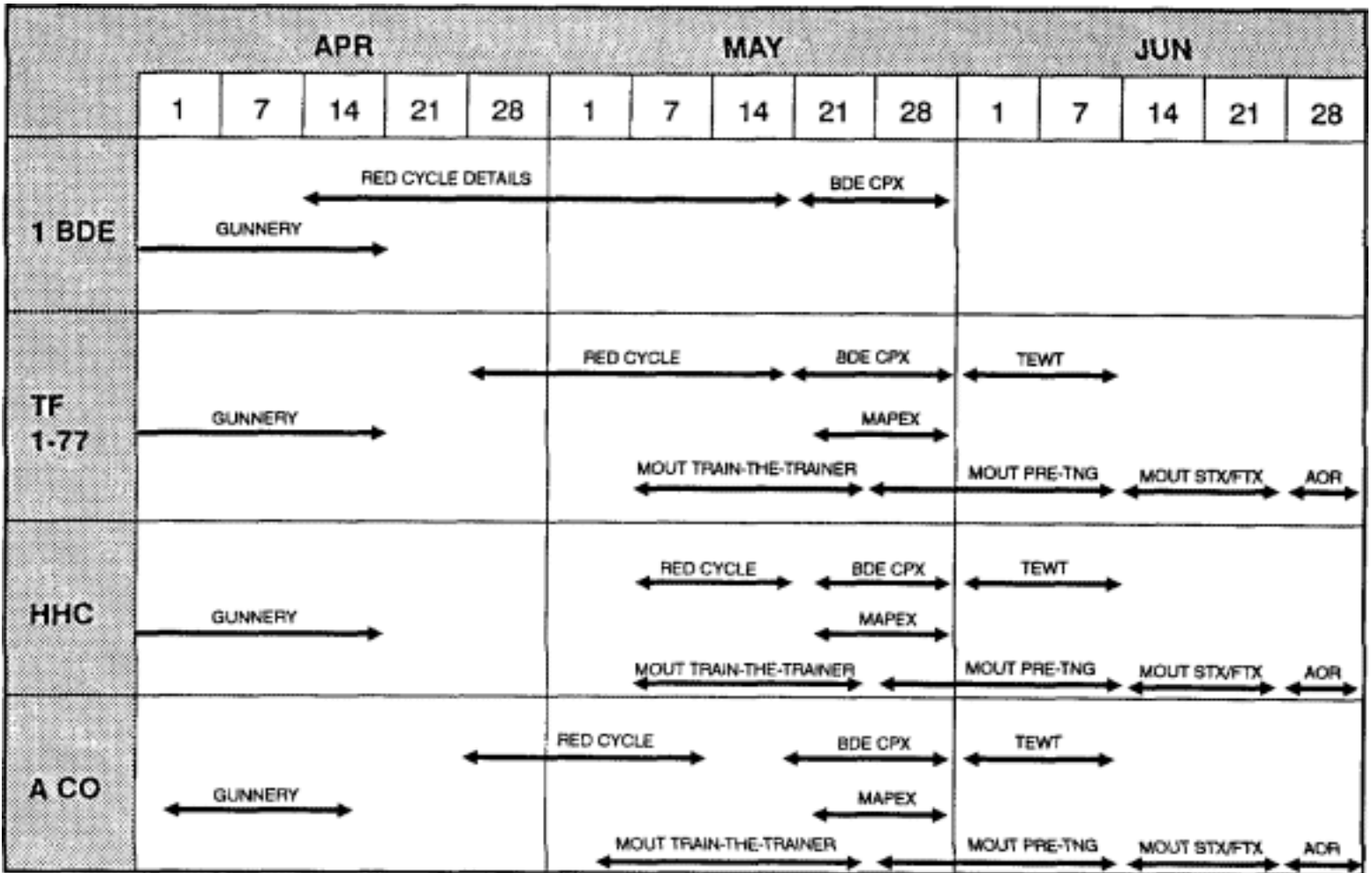

Figure F-2. Short-range training calendar.

### F-3. NEAR-TERM PLANNING

In the near term, the commander must provide specific guidance on the following subjects in the form of an LOI or memorandum:

- Missions.
- Commander's intent.
- Execution and coordination instructions.
- Training phases.
- Ranges and ammunition available.
- AAR requirements.
- Training tasks (all battalion echelons).
- Training tasks (slice units).
- Times for pre-execution checks.
- Detailed training schedules.
- Confirmation of training area requests.
- OPFOR guidance.

- IPR responsibilities.

## **F-4. PRELIMINARY TRAINING**

Preliminary training includes Phases I and II and occurs during the first four weeks of training. Phase I (Weeks 1 and 2) prepares leaders to conduct training and advances soldiers to the *crawl* stage. Phase II (Weeks 3 and 4) consists of prerequisite training and advances soldiers from *crawl* to *walk*. (Figure F-3 provides some example tasks.)

### **BATTALION LEVEL**

- Battalion commander conducts a TEWT along with the company commanders and platoon leaders.
- Battle staff trains to establish the TOC in built-up areas.

### **COMPANY LEVEL**

- Company commanders conduct a MAPEX along with their platoon leaders.
- Company conducts train-the-trainer.

### **PLATOON AND SQUAD LEVEL**

- Platoon leaders develop plans and reconnoiter.
- Platoon sergeants supervise squad training while platoon leaders attend the MAPEX.
- Squads conduct prerequisite training.
- Specialty platoons conduct section training, to include the following:
  - Scout platoon conducts urban reconnaissance and building classification training.
  - TOW platoons select antiarmor positions.
  - Mortar platoon conducts training on emplacement of mortar positions.
  - Communications platoon practices establishing retransmission sites and camouflaging antennas around buildings.

- Medical platoon conducts MEDEVAC training and develops an SOP for evacuating casualties from rubble buildings.
- Maintenance platoon practices establishing a UMCP on a paved surface.
- Support platoon trains drivers in a built-up area.

**Figure F-3. Example preliminary training tasks,  
Phases I and II.**

- a. **Phase I— Weeks 1 and 2.** This phase, which includes leader training and train-the-trainer, prepares leaders for the upcoming MOUT training. It occurs during the first two weeks of the six-week training cycle. The commander should conduct this training around distractors such as post support. Some soldier skill training should also be conducted during Phase I. This depends on the amount of time available and on other training commitments. Pre-execution checks, including physical preparation of soldiers and equipment, should also begin during this phase.
- b. **Phase II— Weeks 3 and 4.** This phase consists of prerequisite MOUT training. Soldiers participate in individual soldier training and small-unit collective training at the same time the battalion commander, staff, subordinate commanders, and platoon leaders participate in the brigade CPX.

## **F-5. TRAINING EXERCISES AND RECOVERY**

Training exercises are conducted in Phases III and IV. In Phase V, the battalion recovers personnel and equipment to combat-readiness. [Figure F-4](#) shows an example battalion training matrix, [Figure F-5](#) shows an example execution and evaluation plan, and [Figure F-6](#) shows an example battalion FTX.

- a. **Phase III—Week 5.** This phase consists of the platoon and company STXs and LFXs. STXs, which are mission-related limited exercises, are designed to train one collective task (or a group of related tasks and drills) through practice. This phase advances training from the *walk* phase to the *run* phase.
- b. **Phase IV—Week 6.** This phase consists solely of the battalion FTX, which goes farther than the STX, integrating the total force in a realistic combat environment.
- c. **Phase V—Week 6.** This phase includes recovery (see unit SOP).

	Week 1 PHASE I	Week 2 PHASE I	Week 3 PHASE II
<b>KEY EVENTS</b>	Train-the-Trainer Leader Training		Prerequisite Training: <ul style="list-style-type: none"> <li>• Individual training</li> <li>• Small-unit collective training</li> <li>• MAPEX (during brigade CPX)</li> </ul>
<b>TASKS, DRILLS, AND TECHNIQUES</b>  (All are tasks or MOUT techniques unless otherwise noted.)	Attend leader development classes on the following subjects: <ul style="list-style-type: none"> <li>• Characteristics of MOUT</li> <li>• Urban mission planning</li> <li>• Movement techniques</li> <li>• Laws of war, rules of engagement</li> </ul>	Select fighting position Enter a building and clear a room Clear a building Breach an obstacle Conduct subterranean operations	Practice the following movement techniques: <ul style="list-style-type: none"> <li>• Move around a corner</li> <li>• Move around or through a window</li> <li>• Negotiate a low wall</li> <li>• Cross an open area</li> <li>• Move around a basement window or mousehole</li> </ul> Practice evacuating casualties in MOUT Construct urban fighting positions Conduct operations IAW laws of war and ROE Practice advanced movement techniques: <ul style="list-style-type: none"> <li>• Negotiate a high wall</li> <li>• Enter upper stories of a building (rappel, use grappling hook)</li> <li>• Perform single and multiple soldier lifts</li> </ul>
 <b>Battle drill</b>			

Figure F-4. Example battalion training matrix.

	<b>Week 1 PHASE I</b>	<b>Week 2 PHASE I</b>	<b>Week 3 PHASE II</b>
<b>RIFLE SQUAD AND PLATOON DRILLS</b>	none	none	none
<b>SPECIALTY PLATOON TASKS</b>  (May need to be adapted for MOUT.)	<b>Scout Platoon:</b> <ul style="list-style-type: none"> <li>• Navigate</li> <li>• Select routes</li> </ul>	<b>Scout Platoon:</b> <ul style="list-style-type: none"> <li>• Provide guides</li> <li>• Select vehicle positions</li> </ul>	<b>Scout Platoon:</b> <ul style="list-style-type: none"> <li>• Perform subterranean reconnaissance</li> <li>• Occupy surveillance positions</li> </ul>
	<b>TOW Platoon:</b> <ul style="list-style-type: none"> <li>• Select TOW firing position</li> </ul>	<b>TOW Platoon:</b> <ul style="list-style-type: none"> <li>• Engage target</li> </ul>	<b>TOW Platoon:</b> <ul style="list-style-type: none"> <li>• Control TOW fires</li> </ul>
	<b>Mortar Platoon:</b> <ul style="list-style-type: none"> <li>• Learn MOUT firing considerations</li> </ul>	<b>Mortar Platoon:</b> <ul style="list-style-type: none"> <li>• Prepare mortar for firing from a hard surface</li> </ul>	<b>Mortar Platoon:</b> <ul style="list-style-type: none"> <li>• Occupy a mortar position</li> </ul>
	<b>Communications Platoon:</b> <ul style="list-style-type: none"> <li>• Erect and camouflage antennas</li> </ul>	<b>Communications Platoon:</b> <ul style="list-style-type: none"> <li>• Perform messenger service</li> </ul>	<b>Communications Platoon:</b> <ul style="list-style-type: none"> <li>• Establish a retransmission site</li> </ul>
	<b>Medical Platoon:</b> <ul style="list-style-type: none"> <li>• Treat and evacuate casualties</li> </ul>	<b>Medical Platoon:</b> <ul style="list-style-type: none"> <li>• Identify health hazards</li> </ul>	<b>Medical Platoon:</b> <ul style="list-style-type: none"> <li>• Treat and evacuate casualties</li> </ul>
	<b>Maintenance Platoon:</b> <ul style="list-style-type: none"> <li>• Learn vehicle maintenance considerations</li> </ul>	<b>Maintenance Platoon:</b> <ul style="list-style-type: none"> <li>• Recover a vehicle from a rubble area</li> </ul>	<b>Maintenance Platoon:</b> <ul style="list-style-type: none"> <li>• Perform a BDAR</li> </ul>

**Figure F-4. Example battalion training matrix (continued).**



	<b>Week 1 PHASE I</b>	<b>Week 2 PHASE I</b>	<b>Week 3 PHASE II</b>
<b>SPECIALTY PLATOON TASKS (continued)</b>	Support Platoon: <ul style="list-style-type: none"> <li>• Practice urban driving skills</li> </ul>	Support Platoon: <ul style="list-style-type: none"> <li>• Prepare a maintenance estimate for MOUT</li> </ul>	Support Platoon: <ul style="list-style-type: none"> <li>• Prepare a logistics package for MOUT</li> </ul>
<b>TRAINING AREA OR FACILITY REQUIRED</b>	none	Collective training facility	Collective training facility
	<b>Week 4 PHASE II</b>	<b>Week 5 PHASE III</b>	<b>Week 6 PHASES IV and V</b>
<b>KEY EVENTS</b>	Prerequisite training: <ul style="list-style-type: none"> <li>• Individual</li> <li>• Small-unit collective</li> <li>• MAPEX (during brigade CPX)</li> </ul>	Company and platoon STXs and LFXs	Phase IV (Days 1 to 3): Battalion FTX  Phase V (Days 4 and 5): after operations recovery
<b>TASKS, DRILLS, AND TECHNIQUES</b>  (All are tasks or MOUT techniques unless otherwise noted.)	Squad: <ul style="list-style-type: none"> <li>• Employ movement techniques</li> <li>• Enter a building and clear a room</li> <li>• React to contact</li> <li>• Breach an obstacle</li> </ul> Platoon: <ul style="list-style-type: none"> <li>• Breach an obstacle</li> <li>• Employ movement techniques</li> </ul>	STX 1: <ul style="list-style-type: none"> <li>• Occupy assembly area</li> <li>• Perform passage of lines</li> <li>• Move tactically</li> <li>• Perform overwatch/support by fire</li> <li>• Breach an obstacle</li> <li>• Clear a building</li> <li>• Perform consolidation and reorganization</li> </ul>	FTX: <ul style="list-style-type: none"> <li>• Occupy assembly area</li> <li>• Perform tactical road march</li> <li>• Perform passage of lines</li> <li>• Move tactically</li> <li>• Defend against air attack</li> <li>• Plan and employ fire support</li> <li>• Breach an obstacle</li> </ul>
 <b>Battle drill</b>			

Figure F-4. Example battalion training matrix (continued).

	Week 4 PHASE II	Week 5 PHASE III	Week 6 PHASE IV and V
	<ul style="list-style-type: none"> <li>• Detect and employ mines, booby traps, and demolitions</li> <li>• React to contact</li> <li>• Assault a building to gain a foothold</li> <li>• Enter and clear a building</li> <li>• Fight from floor to floor</li> <li>• Conduct subterranean operations</li> <li>• Perform consolidation and reorganization</li> <li>• Defend MOUT/building</li> </ul>	<p>STX 2:</p> <ul style="list-style-type: none"> <li>• Move tactically</li> <li>• React to contact</li> <li>• Plan and employ fire support</li> <li>• Clear a building</li> <li>• Perform consolidation and reorganization</li> <li>• Defend MOUT/building</li> </ul> <p>LFX:</p> <ul style="list-style-type: none"> <li>• Perform overwatch/support by fire</li> <li>• Breach an obstacle</li> <li>• Enter a building and clear a room</li> <li>• Perform consolidation and reorganization</li> </ul>	<ul style="list-style-type: none"> <li>• Execute assault</li> <li>• Perform consolidation and reorganization</li> <li>• Execute defense</li> </ul>
RIFLE PLATOON AND SQUAD DRILLS	<p>TRAIN THE FOLLOWING DRILLS EACH WEEK DURING WEEKS 4, 5, AND 6:</p> <ul style="list-style-type: none"> <li>• React to contact</li> <li>• Break contact</li> <li>• React to ambush</li> <li>• Enter a building and clear a room</li> </ul>		
<p>SPECIALTY PLATOON TASKS</p> <p>(May need to be adapted for MOUT.)</p>	<p>Scout Platoon:</p> <ul style="list-style-type: none"> <li>• Provide guides</li> <li>• Perform a screen/guard</li> </ul>	<p>Scout Platoon:</p> <ul style="list-style-type: none"> <li>• Perform reconnaissance</li> <li>• Reconnoiter an obstacle</li> <li>• Assist passage of lines</li> </ul>	<p>Scout Platoon:</p> <ul style="list-style-type: none"> <li>• Perform reconnaissance (route, zone)</li> <li>• Reconnoiter an obstacle</li> <li>• Perform a screen/guard</li> </ul>
<p> Battle drill</p>			

**Figure F-4. Example battalion training matrix (continued).**

	<b>Week 4 PHASE II</b>	<b>Week 5 PHASE III</b>	<b>Week 6 PHASE IV and V</b>
<b>SPECIALTY PLATOON TASKS</b> (continued)  (May need to be adapted for MOUT.)	<b>TOW Platoon:</b>  • Perform overwatch/ support by fire	<b>TOW Platoon:</b>  • Perform a screen/guard  • Provide antiarmor fire to support battalion operations	<b>TOW Platoon:</b>  • Provide antiarmor fire to support battalion operations
	<b>Mortar Platoon:</b>  • Place mortar into action	<b>Mortar Platoon:</b>  • Register and adjust fire	<b>Mortar Platoon:</b>  • Establish radio communications
	<b>Communications Platoon:</b>  • Establish and maintain wire communications	<b>Communications Platoon:</b>  • Establish radio communications	<b>Communications Platoon:</b>  • Establish platoon area of operations
	<b>Medical Platoon:</b>  • Establish triage	<b>Medical Platoon:</b>  • Treat and evacuate casualties	<b>Medical Platoon:</b>  • Establish platoon area of operations
	<b>Maintenance Platoon:</b>  • Provide maintenance support	<b>Maintenance Platoon:</b>  • Recover vehicles	<b>Maintenance Platoon:</b>  • Establish a UMCP
	<b>Support Platoon:</b>  • Establish a field kitchen	<b>Support Platoon:</b>  • Execute logistics package	<b>Support Platoon:</b>  • Provide resupply
<b>TRAINING AREA OR FACILITY</b>	Collective training facility	Collective training facility MOUT assault course	Maneuver area Collective training facility

**Figure F-4. Example battalion training matrix (continued).**

<b>DAY</b>	<b>HOURS</b>	<b>EVENT AND COLLECTIVE TASKS</b>	<b>* SUPPORTING SOLDIER TASKS</b>	<b>OBSERVER-CONTROLLER OR EVALUATOR</b>
1	H+0	Alert unit and load equipment	Perform a function check on M16-series rifle, Dragon, M203 grenade launcher, and M249 LMG Camouflage equipment	CPT Santiago
	H+2	Perform tactical road march	Perform unit maintenance on M2 and M3 BFVs, M1A1 tanks, and M113 APCs	
	H+4	Occupy assembly area	Employ or recover an M18A1 Claymore mine Construct an individual fighting position	
	**H+6	Develop and communicate a plan Prepare for combat	Install communications wire line Prepare and issue oral OPORD Conduct rehearsals	
	H+15	Perform tactical road march	Camouflage equipment Perform search and scan procedures Conduct maneuver of a platoon	
2	H+20	Perform passage of lines	Identify threat weapons Supervise use of night vision devices Plan for use of supporting fires	Cpt Jensen
	H+22	Move tactically	Operate night vision goggles AN/PVS-5 Control movement of a fire team	

\* This is a sample of a task list prepared by the CSM and senior NCOs. Such a list should include tasks for every MOS and skill level (as this list does).

**\*\* These tasks must be conducted simultaneously.**

**Figure F-5. Example execution and evaluation plan.**

DAY	HOURS	EVENT AND COLLECTIVE TASKS	* SUPPORTING SOLDIER TASKS	OBSERVER-CONTROLLER OR EVALUATOR
2	H+26	Defend against air attack	Visually identify threat aircraft Engage hostile aircraft with small arms Report enemy information	
	H+27	Move tactically	Perform movement techniques during MOUT Conduct a leader's reconnaissance	
	**H+30	Breach an obstacle  Plan and employ fire support	Estimate range Move over, through, or around obstacles (except minefields) Neutralize booby traps Locate a target by shift from a known point Call for and adjust fire	
	H+35	Execute an assault (MOUT)	Engage targets with M16-series rifle, M203 grenade launcher, and M249 LMG Select overwatch position Locate mines by visual means	
	**H+40	Perform consolidation Perform reorganization	Select hasty firing positions during MOUT Process enemy prisoners of war/ captured materiel	
3	H+44	AAR		Cpt Schmidt

\* This is a sample of a task list prepared by the CSM and senior NCOs. Such a list should include tasks for every MOS and skill level (as this list does).

**\*\* These tasks must be conducted simultaneously**

These tasks must be conducted simultaneously.

**Figure F-5. Example execution and evaluation plan (continued).**

<b>DAY</b>	<b>HOURS</b>	<b>EVENT AND COLLECTIVE TASKS</b>	<b>* SUPPORTING SOLDIER TASKS</b>	<b>OBSERVER-CONTROLLER OR EVALUATOR</b>
3	H+46	Defend MOUT/building (or conduct second iteration of assault)	Prepare positions for individual and crew-served weapons during MOUT  Issue a fragmentary order  Conduct a defense by a squad	
	H+56	AAR		
	H+60 until completed	Return to garrison and begin Phase V, recovery		
<p>* This is a sample of a task list prepared by the CSM and senior NCOs. Such a list should include tasks for every MOS and skill level (as this list does).</p> <p>** These tasks must be conducted simultaneously.</p>				

**Figure F-5. Example execution and evaluation plan (continued).**

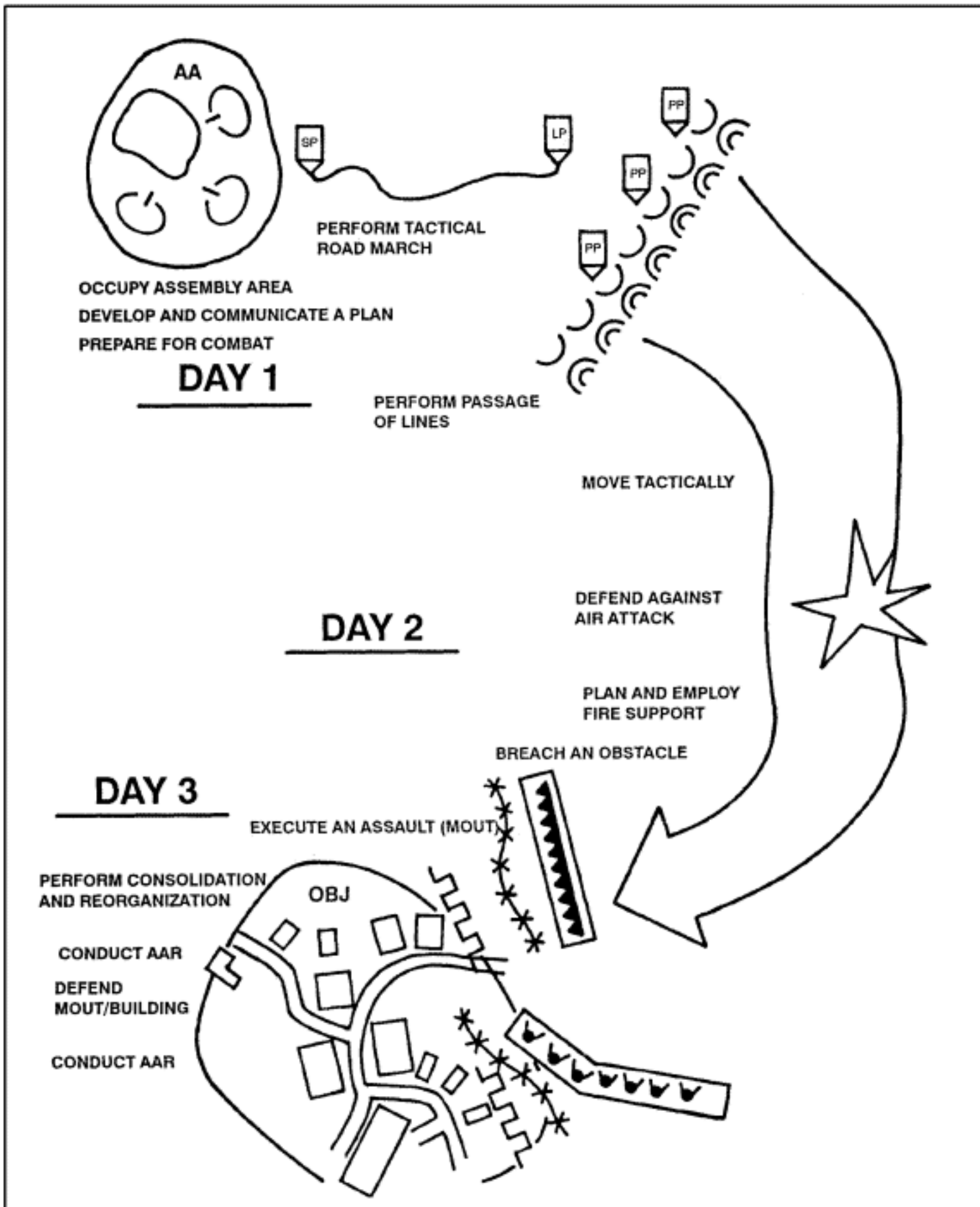

Figure F-6. Example battalion FTX.



# GLOSSARY

AA	assembly area
AAR	after-action review
ADA	air defense artillery
AMTP	Army mission training plan
ANCOC	Advanced Noncommissioned Officer Course
AO	area of operations
AOR	after-operations recovery
APC	armored personnel carrier
ARTEP	Army Training and Evaluation Program
ASAP	as soon as possible
AT	antitank
ATGM	antitank guided missile
ATWESS	antitank weapon effect signature simulator
BDAR	battlefield damage assessment and repair
bde	brigade
BFV	Bradley fighting vehicle
bldg	building
BMNT	beginning morning nautical twilight
bn	battalion
BNCOC	Basic Noncommissioned Officer Course
BP	battle position
BSA	brigade support area
BSX	battle simulation exercise
CAS	close air support
CCP	communications checkpoint
cdr	commander
CEV	combat engineer vehicle
CFA	covering forces area
CFX	command field exercise
CI	counterintelligence
co	company
COA	course of action
catk	counterattack
CP	command post
CPX	command post exercise
CS	combat support
CSM	command sergeant major
CSS	combat service support
CTA	common table of allowances

CTC	combat training center
CTF	collective training facility
decon	decontamination
DODAC	Department of Defense ammunition code
DS	direct support
DTG	date-time group
EA	engagement area
enr	engineer(s)
EOD	explosive ordnance disposal
EST	Eastern standard time
FM	field manual
FO	forward observer
FPF	final protective fires
FRAGO	fragmentary order
FTX	field training exercise
GSR	ground surveillance radar
HC	hexachloroethane
HE	high explosive
HELLFIRE	heliborne laser fire and forget (missile)
HQ	headquarters
hr	hour(s)
IAW	in accordance with
indiv	individual
IN	infantry
INTSUM	intelligence summary
IPB	intelligence preparation of the battlefield
IPR	in-process review
IPW	interrogation of prisoners of war
LAW	light antitank weapon
LD	line of departure
LFX	live-fire exercise
LIC	low-intensity conflict
LO	liaison officer
LOGPAC	logistics package
LOI	letter of instruction
LRC	Leadership Reaction Course

LTC	lieutenant colonel
LZ	loading zone
MAC	MOUT Assault Course
MAPEX	map exercise
MBA	main battle area
MEDEVAC	medical evacuation
METL	mission-essential task list
METT-T	mission, enemy, terrain, troops, and time available
MILES	multiple integrated laser engagement system
min	minute(s)
MOPP	mission-oriented protective posture
MOS	military occupational specialty
MOUT	military operations on urbanized terrain
MP	military police
MRB	motorized rifle battalion
MRD	motorized rifle division
MRE	meal, ready-to-eat
MRR	motorized rifle regiment
MTC	MOUT training complex
MTP	mission training plan
NBC	nuclear, biological, chemical
NCO	noncommissioned officer
NCOIC	noncommissioned officer in charge
NLT	no later than
NVD	night vision device
OAC	Officer Advanced Course
OAKOC	obstacles, avenues of approach, key terrain, observation and fields of fire, and cover and concealment
OBC	Officer Basic Course
obj	objective
OP	observation post
OPCON	operational control
OPFOR	opposing force
OPORD	operation order
OPP	officer professional program
OPSKED	operational schedule
PADS	position and azimuth determining system
PL	phase line
plt	platoon

POI	program of instruction
prepn	preparation
PSYOP	psychological operations
PW	prisoner of war
PZ	pickup zone
recon	reconnoiter or reconnaissance
RP	release point
RPG	rocket-propelled grenade
RPK	(Threat weapon)
SBF	support by fire
SOF	special operations force
SOI	signal operation instruction
SOP	standing operating procedure
sqd	squad
SQT	skill qualification test
STP	soldier training publication
STX	situational training exercise
T&EO	training and evaluation outline
TACSOP	tactical standing operating procedure
TBA	to be announced
TBD	to be determined
TC	training circular
TCP	traffic control post
TEWT	tactical exercise without troops
TF	task force
tm	team
TOC	tactical operations center
TOW	tube-launched, optically tracked, wire-guided missile
TP	training practice
TRP	target reference point
TSC	Training Support Center
TTP	tactics, techniques, and procedures
UMCP	unit maintenance collection point
Viper	a MILES force-on-force trainer for light antiarmor weapons
WP	white phosphorus
XO	executive officer

# REFERENCES

## SOURCES USED

*These are the sources quoted or paraphrased in this manual:*

- FM 1-100. Doctrinal Principles for Army Aviation in Combat Operations. 28 February 1989.
- FM 1-112. Tactics, Techniques, and Procedures for the Attack Helicopter Battalion. 21 February 1991.
- FM 5-33. Terrain Analysis. 11 July 1990.
- FM 5-101. Mobility. 23 January 1985.
- FM 5-102. Countermobility. 14 March 1985.
- FM 5-103. Survivability. 10 June 1985.
- FM 6-20. Fire Support in the AirLand Battle. 17 May 1988.
- FM 6-20-40. Tactics, Techniques, and Procedures for Fire Support for Brigade Operations (Heavy). 5 January 1990.
- FM 6-20-50. Tactics, Techniques, and Procedures for Fire Support for Brigade Operations (Light). 5 January 1990.
- FM 7-10. The Infantry Rifle Company. 14 December 1990.
- FM 7-20. The Infantry Battalion. 6 April 1992.
- FM 7-30 (HTF). Infantry Airborne and Air Assault Brigade (How to Fight). 24 April 1981.
- FM 7-98. Operations in Low-Intensity Conflict, 19 October 1992.
- FM 20-3. Camouflage. 14 November 1990.
- FM 21-18. Foot Marches. 1 June 1990.
- FM 23-25. Launcher and Cartridge, 84-MM, M136 (AT4), HEAT. 22 November 1988.
- FM 23-30. Grenades and Pyrotechnic Signals. 27 December 1988.
- FM 23-33. 66-MM HEAT Rocket M72AI and M72A2 (LAW). 20 April 1979.
- FM 24-1. Signal Support in the AirLand Battle. 15 October 1990.
- FM 25-5. Training for Mobilization and War. 25 January 1985.
- FM 25-100. Training the Force. 15 November 1988.

FM 25-101. Battle Focused Training. 30 September 1990.

FM 71-1. Tank and Mechanized Infantry Company Team. 22 November 1988.

FM 71-2. The Tank and Mechanized Infantry Battalion Task Force. 27 September 1988.

FM 71-3. Armored and Mechanized Infantry Brigade. 11 May 1988.

FM 100-5. Operations. 5 May 1986.

FM 100-20. Military Operations in Low Intensity Conflict. 5 December 1990.

FM 101-5-1. Operational Terms and Symbols. 21 October 1985.

## **DOCUMENTS NEEDED**

*These documents must be available to the intended users of this publication:*

ARTEP 7-8-Drill. Battle Drills for the Infantry Rifle Platoon and Squad. 22 January 1990.

ARTEP 7-8-MTP. Mission Training Plan for the Infantry Rifle Platoon and Squad. 30 September 1988.

ARTEP 7-10-MTP. Mission Training Plan for the Infantry Rifle Company. 3 October 1988.

ARTEP 7-20-MTP. Mission Training Plan for the Infantry Battalion. 27 December 1988.

ARTEP 7-30-MTP. Mission Training Plan for the Infantry Brigade (Command Group/Staff). 17 February 1989.

FM 7-7. The Mechanized Infantry Platoon and Squad (APC). 15 March 1985.

FM 7-7J. The Mechanized Infantry Platoon and Squad (Bradley). 18 February 1986.

FM 7-8. Infantry Rifle Platoon and Squad. 22 April 1992.

FM 25-4. How to Conduct Training Exercises. 10 September 1984.

FM 34-130. Intelligence Preparation of the Battlefield. 23 May 1989.

\*FM 90-10 (HTF). Military Operations on Urbanized Terrain (MOUT) (How to Fight). 15 August 1979.

\*FM 90-10-1. Infantryman's Guide to Combat in Built-Up Areas. 12 May 1993.

STP 7-11BCHM14-SM-TG. Soldier's Manual, Skill Levels 1/2/3/4, and Trainer's Guide, CMF 11, Infantry. 30 September 1988.

STP 21-1-SMCT. Soldier's Manual of Common Tasks, Skill Level 1. 1 October 1990.

STP 21-24-SMCT. Soldier's Manual of Common Tasks, Skill Levels 2/3/4. 1 October 1992.

TC 7-9. Infantry Live-Fire Training. 9 July 1993.

---

\* This source was also used to develop this publication.

---

## **READINGS RECOMMENDED**

*These readings contain relevant supplemental information:*

### **Army Publications**

AR 310-25. Dictionary of United States Army Terms. 15 October 1983.

AR 310-50. Authorized Abbreviations and Brevity Codes. 15 November 1985.

AR 385-62. Regulations for Firing Guided Missiles and Heavy Rockets for Training, Target Practice, and Combat. 5 January 1977.

AR 385-63. Policies and Procedures for Firing Ammunition for Training, Target Practice, and Combat. 15 October 1983.

AR 600-8-1. Army Casualty and Memorial Affairs and Line of Duty Investigations. 18 September 1986.

FM 3-3. NBC Contamination Avoidance. 30 September 1986.

FM 3-4. NBC Protection. 29 May 1992.

FM 3-5. NBC Decontamination. 23 July 1992.

FM 3-6. Field Behavior of NBC Agents (Including Smoke and Incendiaries). 3 November 1986.

FM 3-9. Potential Military Chemical/Biological Agents and Compounds. 12 December 1990.

FM 3-11. Flame Field Expedients. 19 September 1990.

FM 3-100. NBC Defense, Chemical Warfare, Smoke, and Flame Operations. 23 May 1991.

FM 5-34. Engineer Field Data. 14 September 1987.

FM 5-105. Topographic Operations. 9 September 1987.

FM 5-250. Explosives and Demolitions. 15 June 92.

FM 7-90. Tactical Employment of Mortars. 11 June 1985.

FM 7-91. Tactical Employment of Antiarmor Platoons, Companies, and Battalions. 30 September 1987.

FM 10-63. Handling of Deceased Personnel in Theaters of Operations. 28 February 1986.

FM 10-63-1. Graves Registration Handbook. 17 July 1986.

FM 11-50. Combat Communications Within the Division (Heavy and Light). 4 April 1991.

- FM 17-95. Cavalry Operations. 19 September 1991.
- FM 17-98. Scout Platoon. 7 October 1987.
- >FM 19-1. Military Police Support for the AirLand Battle. 23 May 1988.
- FM 19-15. Civil Disturbances. 25 November 1985.
- FM 19-30. Physical Security. I March 1979.
- FM 19-40. Enemy Prisoners of War, Civilian Internees, and Detained Persons. 27 February 1976.
- FM 20-32. Mine/Countermine Operations. 9 December 1985.
- FM 21-10. Field Hygiene and Sanitation. 22 November 1988.
- FM 21-11. First Aid for Soldiers. 27 October 1988.
- FM 21-20. Physical Fitness Training. 30 September 1992.
- FM 21-60. Visual Signals. 30 September 1987.
- FM 21-75. Combat Skills of the Soldier. 3 August 1984.
- FM 23-1. Bradley Fighting Vehicle Gunnery. 1 March 1991.
- FM 23-9. M116A1 Rifle and M16A2 Rifle Marksmanship. 3 July 1989.
- FM 27-10. The Law of Land Warfare. 18 July 1956.
- FM 33-1. Psychological Operations. 31 July 1987.
- FM 34-1. Intelligence and Electronic Warfare Operations. 2 July 1987.
- FM 34-3. Intelligence Analysis. 15 March 1990.
- FM 44-1. US Army Air Defense Artillery Employment. 9 May 1983.
- FM 44-3. Air Defense Artillery Employment: Chaparral/Vulcan/Stinger. 15 June 1984.
- FM 41-10. Civil Affairs Operations. 17 December 1985.
- FM 44-16. Chaparral/Vulcan/Stinger Platoon Combat Operations. 29 May 1987.
- FM 63-1. Combat Service Support Operations, Separate Brigade. 30 September 1983.
- FM 63-2. Division Support Command, Armored, Infantry, and Mechanized Infantry Divisions. 20 May 1991.
- FM 71-100. Division Operations. 16 June 1990.
- FM 71-101 (HTF). Infantry, Airborne, and Air Assault Division Operations (How to Fight). 26 March 1980.

- FM 90-2. Battlefield Deception. 3 October 1988.
- FM 100-2-1. The Soviet Army: Operations and Tactics. 16 July 1984.
- FM 100-2-2. The Soviet Army: Specialized Warfare and Rear Area Support. 16 July 1984.
- FM 100-2-3. The Soviet Army: Troops, Organization, and Equipment. 6 June 1991.
- FM 100-10. Combat Service Support. 18 February 1988.
- FM 100-26. The Air-Ground Operations System. 30 March 1973.
- FM 101-5. Staff Organization and Operations. 25 May 1984.
- FM 101-10-1/1. Staff Officers Field Manual—Organizational, Technical, and Logistical Data (Volume 1). 7 October 1987.
- FM 101-10-1/2. Staff Officers Field Manual—Organizational, Technical, and Logistical Data (Volume 2). 7 October 1987.
- FM 700-80. Logistics. 15 August 1985.
- HNDM 1110-1-7. The Design Manual for Military Operations on Urbanized Terrain (MOUT) Training Complex. September 1988.
- TC 24-20. Tactical Wire and Cable Techniques. 3 October 1988.
- TC 34-40-6. Signal Intelligence (SIGINT). 11 April 1989.
- TC 90-6-1. Military Mountaineering. 26 April 1989.

### **Nonmilitary Publications**

Anders, W

*An Army in Exile.*

London: Macmillan and Company, LTD. 1949.

Bauer, C.

*The Battle of Arnhem.*

New York: Stein and Day Publishers. 1967.

Carell, P.

*Hitler Moves East 1941-1943.* Boston (first American edition): Little, Brown, and Company. 1964.

Chuikov, V.I.

*The Fall of Berlin.*

New York: Holt, Rinehart, and Winston. 1967.

Clark, A.

*Barbarossa: the Russian-German Conflict 1941-1945.*

New York: William Morrow and Company. 1965.

Cole, H.M.

*U.S. Army in WWII—European Theater of Operations—The Ardennes: Battle of the Bulge.*

U.S. Government Printing Office. 1965.

Connell, C.

*Monte Cassino.*

London: Elek Books Limited. 1963.

Cuthbert, S.J.

*We Shall Fight in the Streets.*

Boulder, Colorado: Panther Publications. 1965.

Czarnomski, E.B., ed.

*They Fight for Poland; the War in the First Person.*

London: George Allen and Union LTD. 1941.

Finkelstein, S.

*Regiment of the Century: The Story of the 397th Infantry Regiment.*

Stuttgart, Germany: Union Druckerei GMBH. 1945.

Flower, D.J.N. and Reeves, J.

*The War, 1939 - 1945, "Stalingrad."*

London: Cassell and Company LTD. 1960.

Fuermann, G.M.

*95th Infantry Division History, 1918-1946.*

Atlanta: Albert Love Enterprises. Not dated.

Goerlitz, W.

*Paulus and Stalingrad.*

New York: The Citadel Press (first American edition). 1963.

Gouré, L.

*The Seige of Leningrad.*

New York: Stanford University Press. 1962.

Hibbert, C.

*The Battle of Arnhem.*

London: B.T. Batsford, LTD. 1962.

Korbonski, S.

*Fighting Warsaw; the Story of the Polish Underground State.*

London: George Allen and Unwin, LTD. 1956.

Kuby, E.

*The Russians and Berlin.*

New York: Hill and Wang. 1968.

Hart Liddell, B.H., ed.

*The Rommel Papers.*

New York: Harcourt, Brace, and Company. 1953.

Lyman, W.J.

*Curlew History, the Story of the 1st Battalion, 117th Infantry, 30th Division in Europe during World War II.*

Chapel Hill: The Orange Printshop. 1948.

Mackenzie, F.

*The Men of Bastogne.*

New York: David McKay Publishing Company. 1968.

Majdalany, E.

*The Battle of Cassino.*

Boston: Houghton Mifflin Company. 1957.

Manstein, E.V.

*Lost Victories.*

Chicago: Henry Regency Company. 1958.

Marshall, S.L.A.

*Bastogne (the story of the first eight days, in which the 101st Airborne Division was closed within the ring of German forces).*

Washington: Infantry Journal Press (first edition). 1946.

Munsell, W.P., Jr.

*The Story of a Regiment; a History of the 179th Regimental Combat Team.*

San Angelo, Texas: Newsfoto Publishing. 1946.

Oppenheimer, M.

*The Urban Guerrilla.*

Chicago: Quadrangle Books. 1969.

Rubel, G.K.

*Daredevil Tankers.*

Werk-Gottingen, Germany: "Muster-Schmidt," Limited. 1945.

Ryan, C.

*The Last Battle.*

New York: Simon and Schuster. 1966.

Schroter, H.

*Stalingrad.*

New York: E.P. Dutton and Company, Inc. 1958.

Seth, R.

*Stalingrad: Point of Return; The Story of the Battle.*

New York: Coward-McCann. 1959.

Taggart, D.G., ed.

*History of the 3d Infantry Division in WWII.*

Washington: Infantry Journal Press. 1947.

Toland, J.

*Battle; the Story of the Bulge.* New York: Random House. 1959.

Toland, J.

*The Last 100 Days.*

New York: Random House. 1966.

Wade, G.A.

*Defense of Villages and Small Towns.*

Aldershot, Gale, and Polden, Limited. Possibly published in 1942.

Wade, G.A.

*House to House Fighting.*

Aldershot, Gale, and Polden, Limited. Possibly published in 1942.

Werstein, I.

*The Battle of Jacken.*

New York: Thomas Y. Crowell Company. 1962.

Werth, A.

*Russia at War 1941-1945.*

New York: EY Dutton and Company, Incorporated. 1964.

White, N.W

*From Fedala to Berchtesgaden; a History of the 7th U.S. Infantry.*

Brockton, Massachusetts: Keystone Print Inc. 1947.

**TC 90-1**  
**30 SEPTEMBER 1993**

By Order of the Secretary of the Army:

**GORDON R. SULLIVAN**  
*General, United States Army*  
*Chief of Staff*

Official:

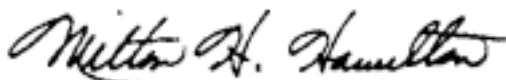

MILTON H. HAMILTON  
*Administrative Assistant to the*  
*Secretary of the Army*

04932

**DISTRIBUTION:** Active Army, USAR, and ARNG: To be distributed in accordance with DA Form 12-11E, requirements for TC 90-1, Training for Military Operations on Urbanized Terrain (Qty rqr block no. 3858).

\*U.S. Government Printing Office: 1993 — 728-027/80057